

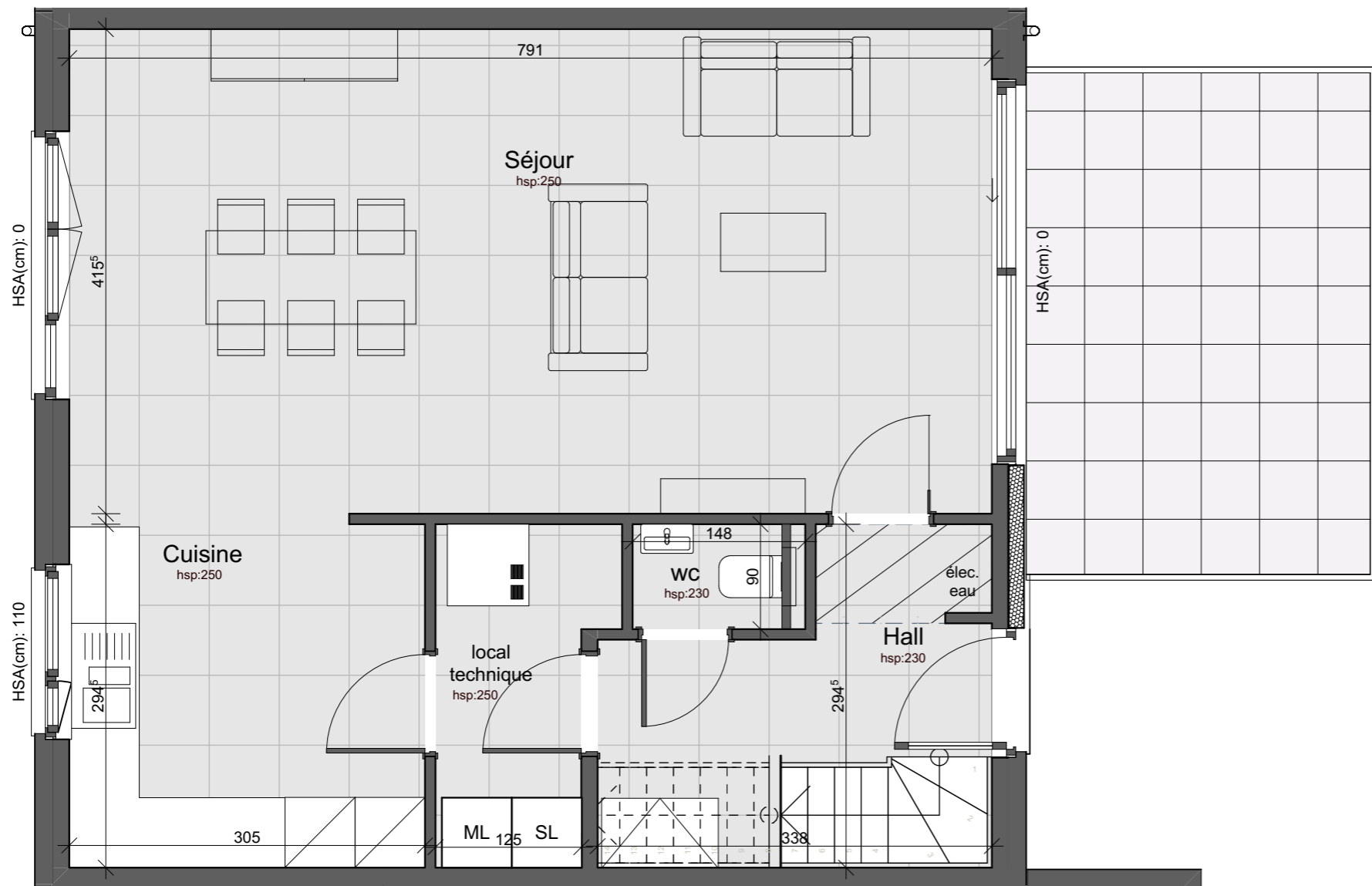

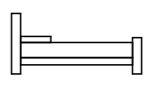

les deux écluses



MAISON - LOT 05 (Type 3)		
Niveau +0		
 3	 1	 127.6 m ²
 176 m ²	 37.6 m ²	

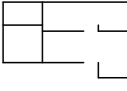

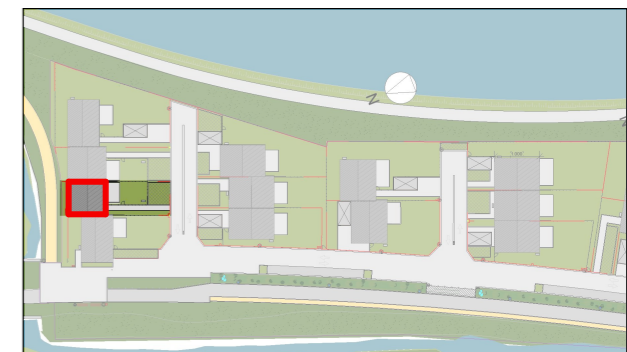
Rue Jean-Baptiste Vifquin
7180 Seneffe





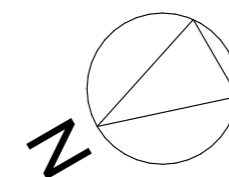

Drève Richelle, 161 D bte 19
B-1410 Waterloo
02 897 52 65 - www.equilis.net

- Document à titre d'information et non contractuel.
- Mobilier, machine à laver (ML) et sèche-linge (SL) non fournis.
- Les dimensions des cuisines et de leurs équipements sont données à titre d'information. Se référer aux plans contractuels des cuisines.
- Des faux-plafonds complémentaires pourront être placés à certains endroits pour des raisons techniques.
- Dimensions (distance entre murs avant plafonnage) données à titre indicatif.
- Ce qui est repris en pointillés sur les plans (vélux, aménagement des combles, etc.) n'est pas compris dans la vente.

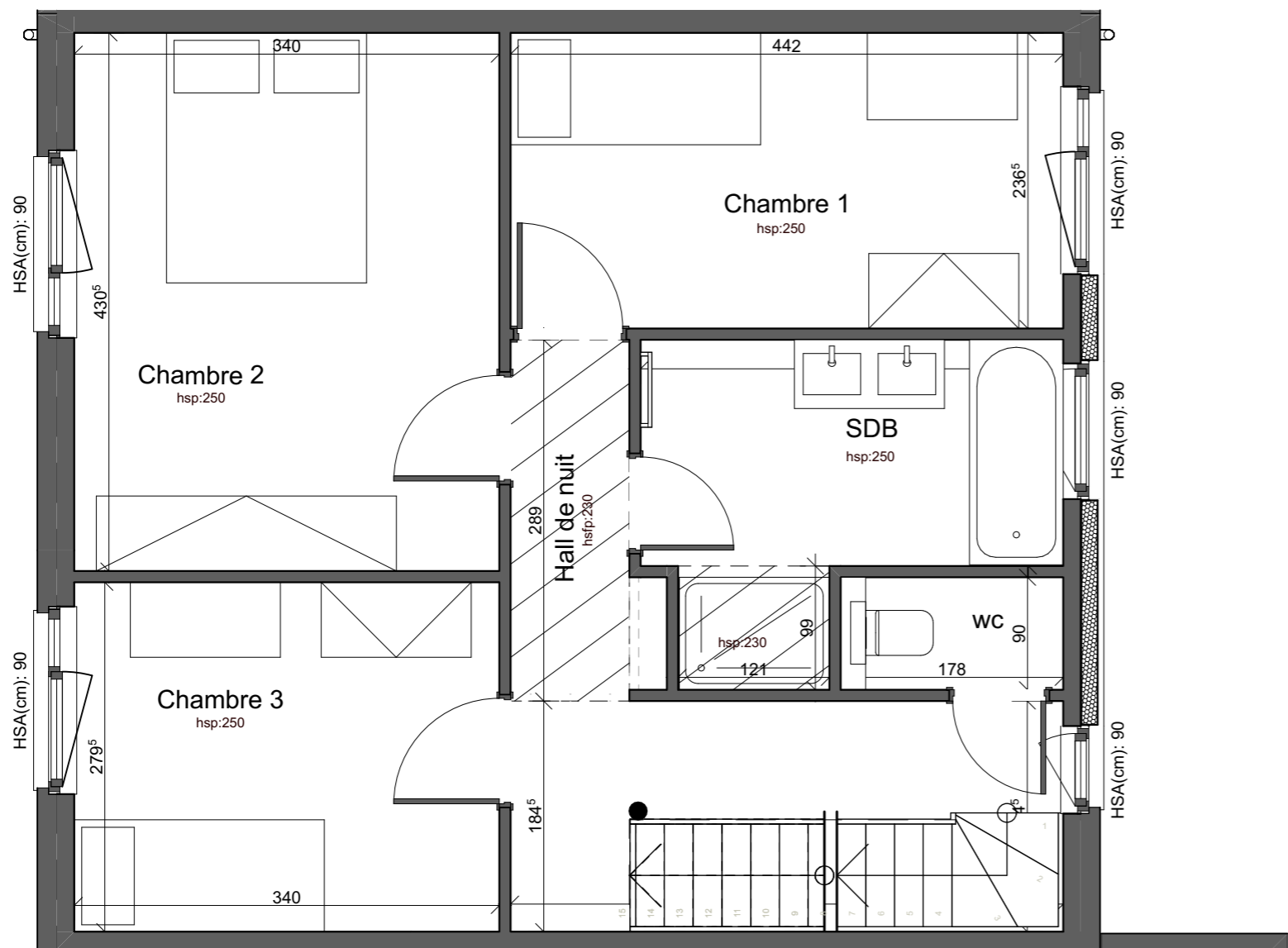

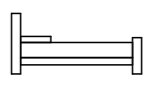
les deux
écluses

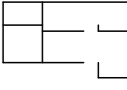

MAISON - LOT 05 (Type 3)		
Niveau +1		
 3	 1	 127.6 m ²
 176 m ²	 37.6 m ²	







Rue Jean-Baptiste Vifquin
7180 Seneffe

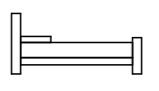

Drève Richelle, 161 D bte 19
B-1410 Waterloo
02 897 52 65 - www.equilis.net

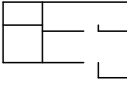
les deux
écluses

MAISON - LOT 05 (Type 3)		
Niveau +2		
 3	 1	 127.6 m ²
 176 m ²	 37.6 m ²	



Rue Jean-Baptiste Vifquin
7180 Seneffe

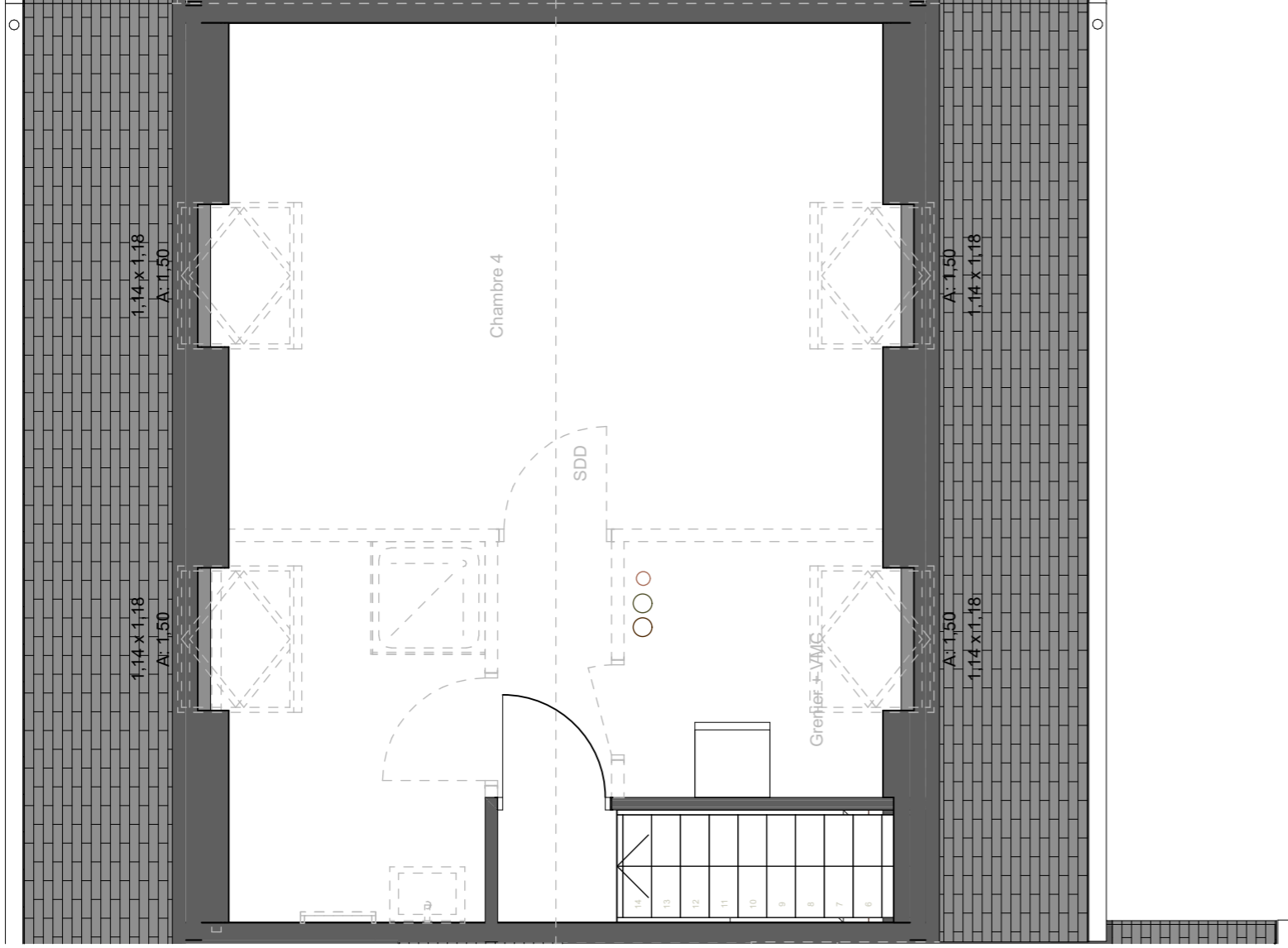

les deux

écluses

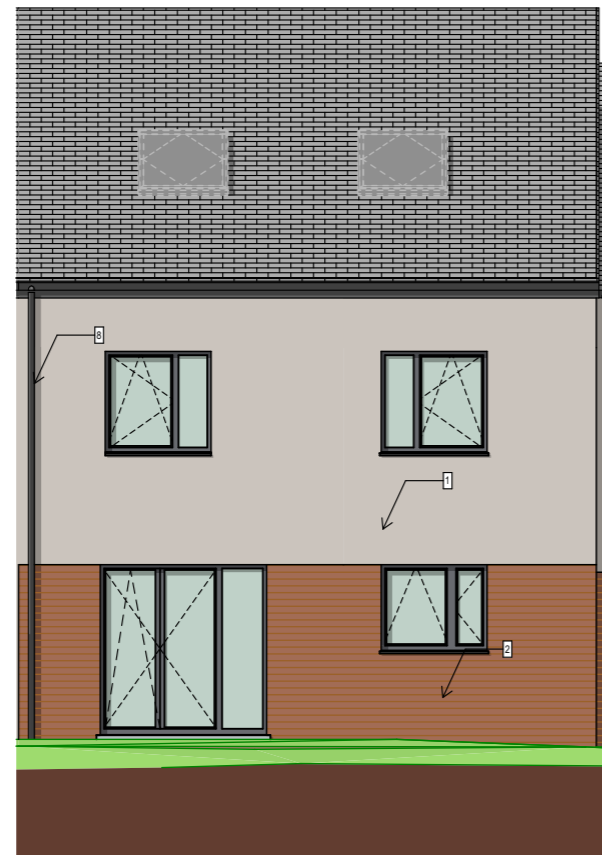

ELEVATIONNORD





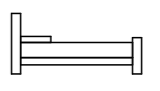
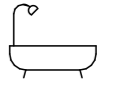
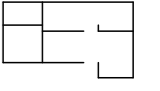
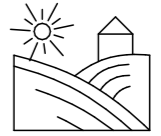
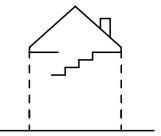

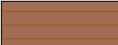

ELEVATIONSUD

MAISON - LOT 05 (Type 3)		
Elévations		
 3	 1	 127.6 m ²
 176 m ²	 37.6 m ²	

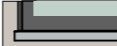

Rue Jean-Baptiste Vifquin
7180 Seneffe

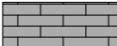

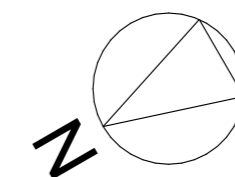

-  Crépis lotusan de teinte blanche
-  Briquette synthétique STO teinte brun-gris
-  Châssis PVC de teinte anthracite
-  Bandeau métallique anthracite de liaison entre fenêtres

-  seuil pierre-bleue
-  rive: tuile micro-béton et plaque cedral board anthracite
-  Toiture en tuile micro-béton anthracite
-  gouttière et descentes d'eau zinc anthrazinc

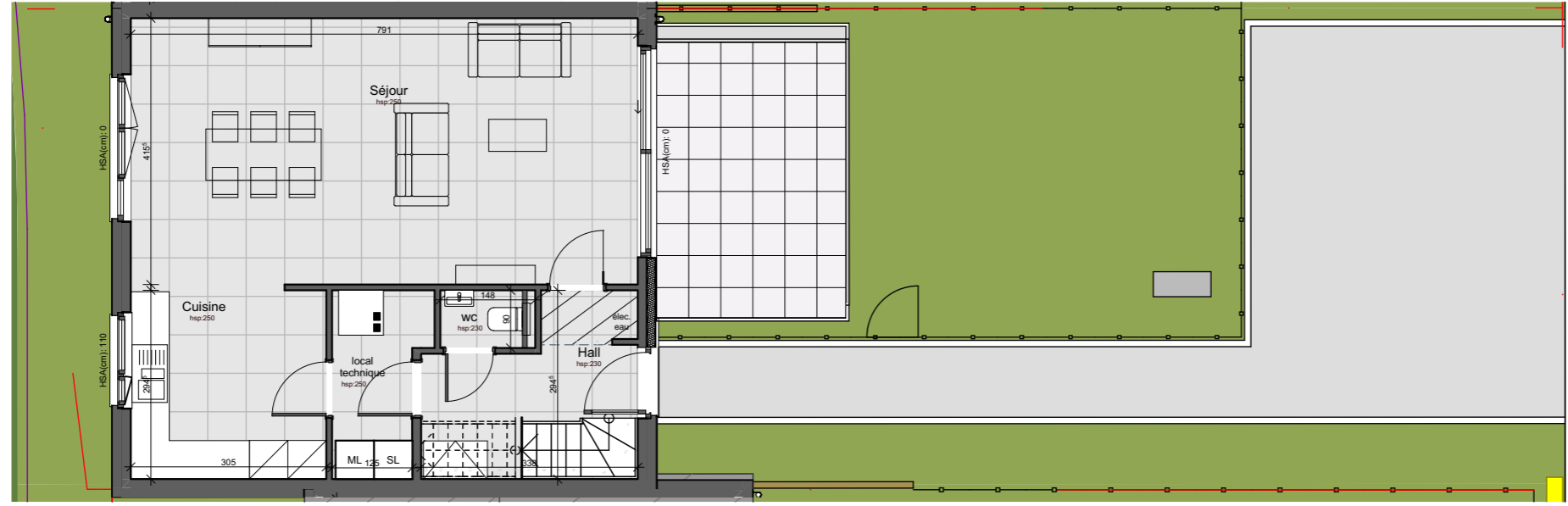

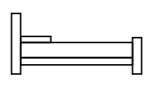
les deux
écluses

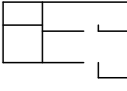

MAISON - LOT 05 (Type 3)		
Implantation		
 3	 1	 127.6 m ²
 176 m ²	 37.6 m ²	

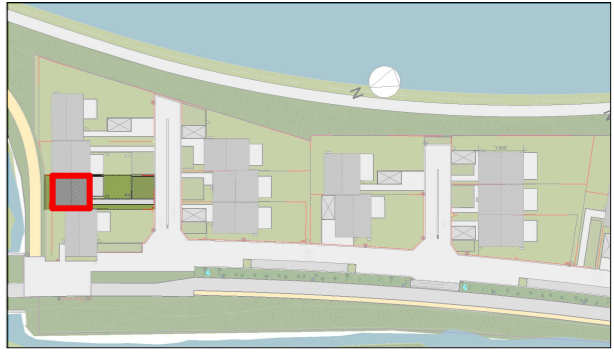

Rue Jean-Baptiste Vifquin
7180 Seneffe

- 

Borbure en béton
- 

Portail métallique
- 

Pavés de béton drainant
- 

Haie



Drève Richelle, 161 D bte 19
B-1410 Waterloo
02 897 52 65 - www.equilis.net