

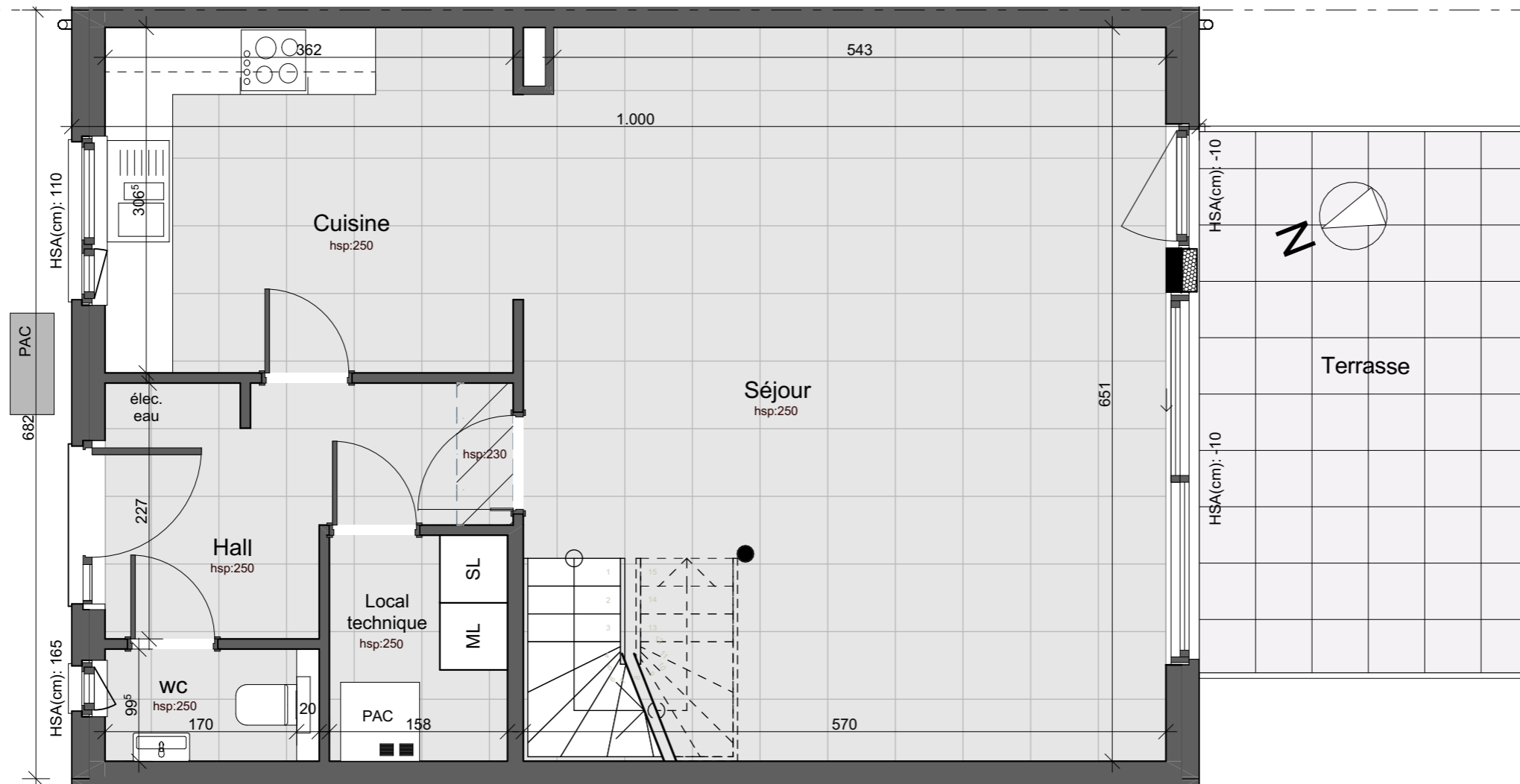

les deux

écluses

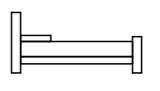
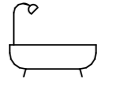
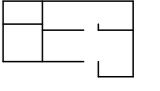

MAISON - LOT N2 (Type 5 bis)		
Niveau +0		
 3	 2	 136.4 m <sup>2</sup>
 212 m <sup>2</sup>	 44.5 m <sup>2</sup>	

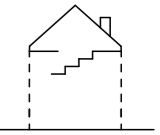

Rue Jean-Baptiste Vifquin  
7180 Senefle



Drève Richelle, 161 D bte 19  
B-1410 Waterloo  
02 897 52 65 - www.equilis.net

- Document à titre d'information et non contractuel.
- Mobilier, machine à laver (ML) et sèche-linge (SL) non fournis.
- Les dimensions des cuisines et de leurs équipements sont données à titre d'information. Se référer aux plans contractuels des cuisines.
- Des faux-plafonds complémentaires pourront être placés à certains endroits pour des raisons techniques.
- Dimensions (distance entre murs avant plafonnage) données à titre indicatif.
- Ce qui est repris en pointillés sur les plans (vélux, aménagement des combles, etc.) n'est pas compris dans la vente.

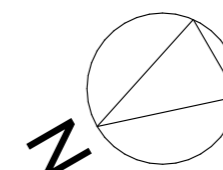

Echelle: 1:50

MIS A JOUR LE: / /  
POUR ACCORD:  
DATE

SIGNATURE:

  
M. Rahir architecte  
le 19/06/2026



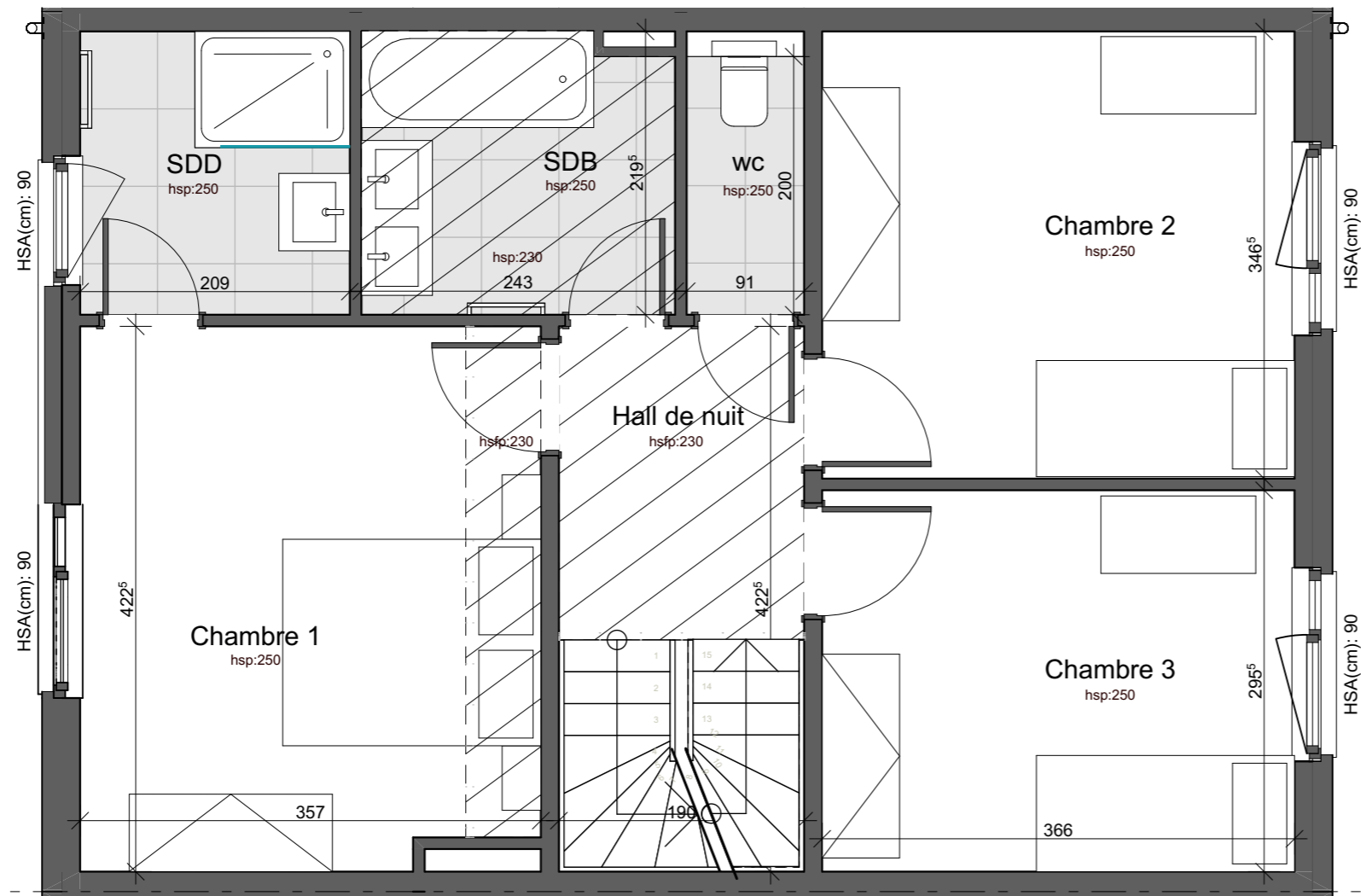

les deux

écluses

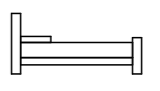

MAISON - LOT N2 (Type 5 bis)

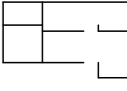
Niveau +1

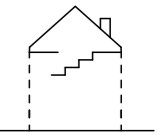
 3	 2	 136.4 m <sup>2</sup>
 212 m <sup>2</sup>	 44.5 m <sup>2</sup>	



Rue Jean-Baptiste Vifquin  
7180 Seneffe



Drève Richelle, 161 D bte 19  
B-1410 Waterloo  
02 897 52 65 - www.equilis.net

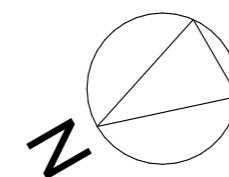

- Document à titre d'information et non contractuel.
- Mobilier, machine à laver (ML) et sèche-linge (SL) non fournis.
- Les dimensions des cuisines et de leurs équipements sont données à titre d'information. Se référer aux plans contractuels des cuisines.
- Des faux-plafonds complémentaires pourront être placés à certains endroits pour des raisons techniques.
- Dimensions (distance entre murs avant plafonnage) données à titre indicatif.
- Ce qui est repris en pointillés sur les plans (vélux, aménagement des combles, etc.) n'est pas compris dans la vente.

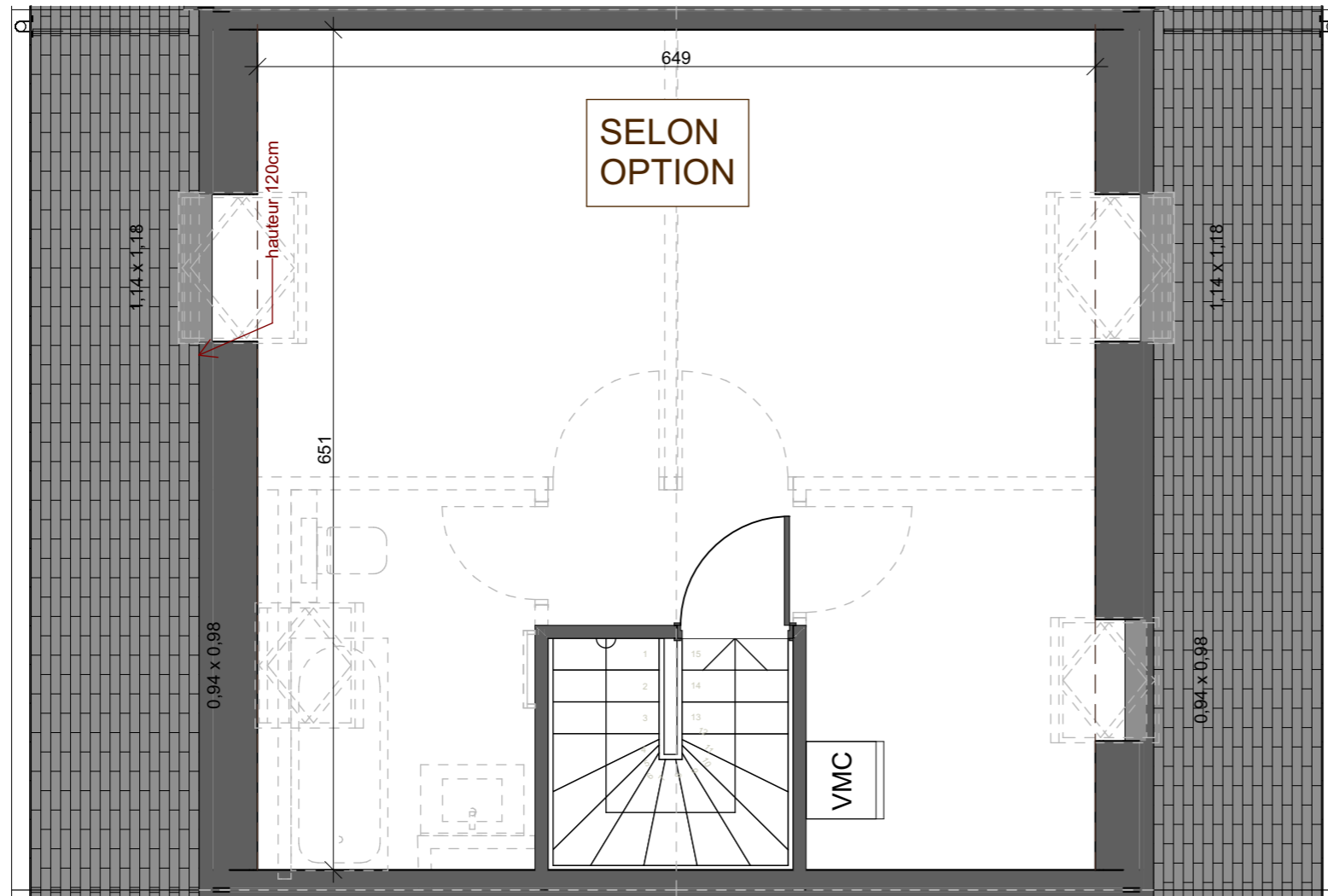

les deux

écluses

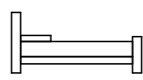
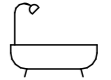
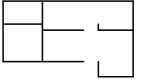

MAISON - LOT N2 (Type 5 bis)		
Niveau +2		
 3	 2	 136.4 m <sup>2</sup>
 212 m <sup>2</sup>	 44.5 m <sup>2</sup>	



Rue Jean-Baptiste Vifquin  
7180 Seneffe



Drève Richelle, 161 D bte 19  
B-1410 Waterloo  
02 897 52 65 - www.equilis.net

- Document à titre d'information et non contractuel.
- Mobilier, machine à laver (ML) et sèche-linge (SL) non fournis.
- Les dimensions des cuisines et de leurs équipements sont données à titre d'information. Se référer aux plans contractuels des cuisines.
- Des faux-plafonds complémentaires pourront être placés à certains endroits pour des raisons techniques.
- Dimensions (distance entre murs avant plafonnage) données à titre indicatif.
- Ce qui est repris en pointillés sur les plans (vélux, aménagement des combles, etc.) n'est pas compris dans la vente.

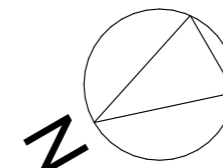

Echelle: 1:50

MIS A JOUR LE: / /  
POUR ACCORD:  
DATE

SIGNATURE:

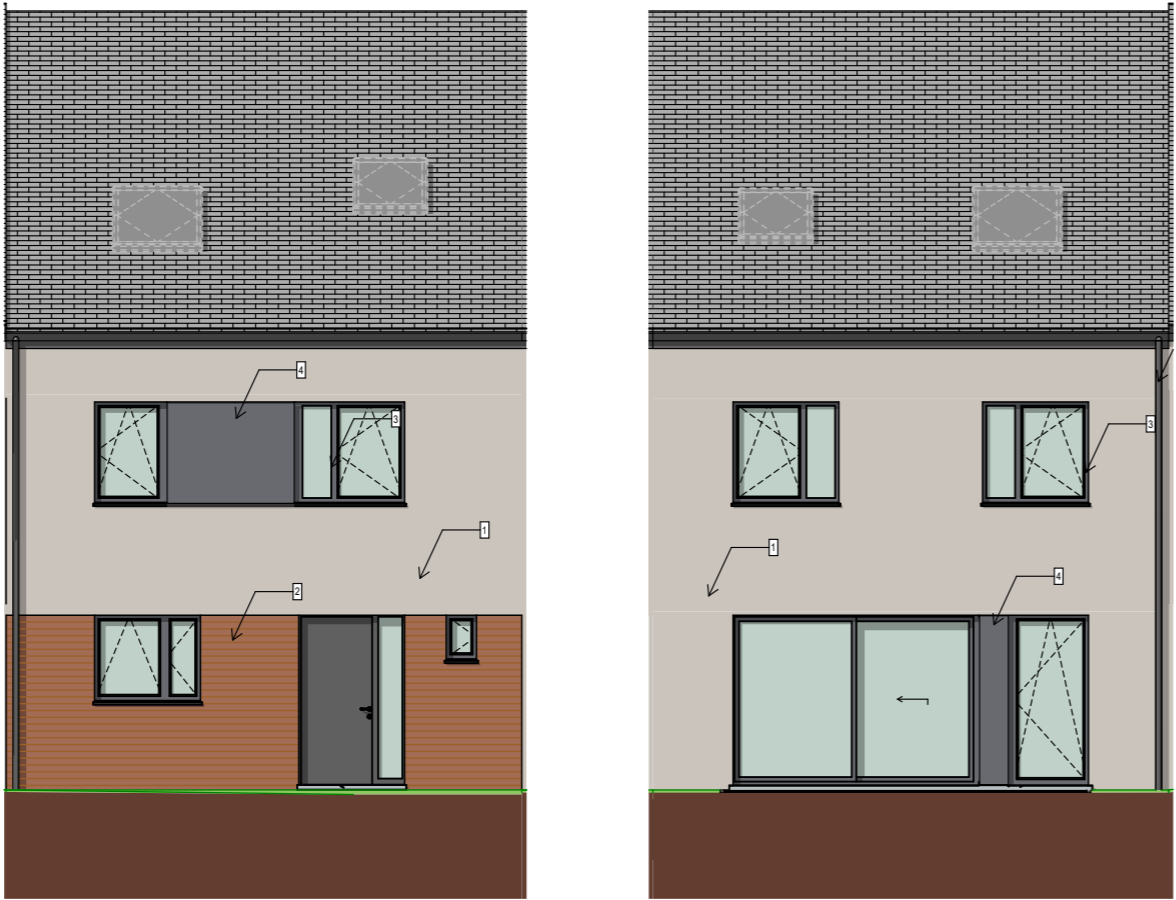

  
M. Rahir architecte  
le 19/06/2026

les deux  
écluses



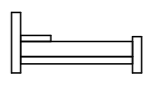
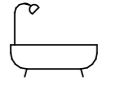
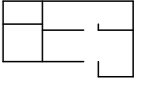

ELEVATIONNORD

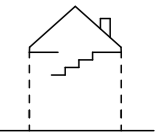
ELEVATIONSUD

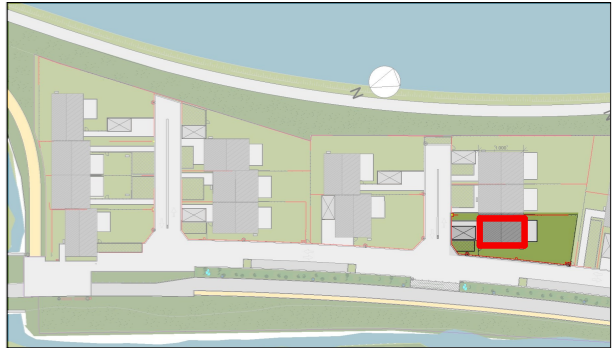
MAISON - LOT N2 (Type 5 bis)		
Elévations		
 3	 2	 136.4 m <sup>2</sup>
 212 m <sup>2</sup>	 44.5 m <sup>2</sup>	





Rue Jean-Baptiste Vifquin  
7180 Seneffe

-  Crépis lotusan de teinte blanche
-  seuil pierre-bleue
-  Briquette synthétique STO teinte brun-gris
-  Châssis PVC de teinte anthracite
-  rive: tuile micro-béton et plaque cedral board anthracite
-  Bandeau métallique anthracite de liaison entre fenêtres
-  Toiture en tuile micro-béton anthracite
-  gouttière et descentes d'eau zinc anthrazinc

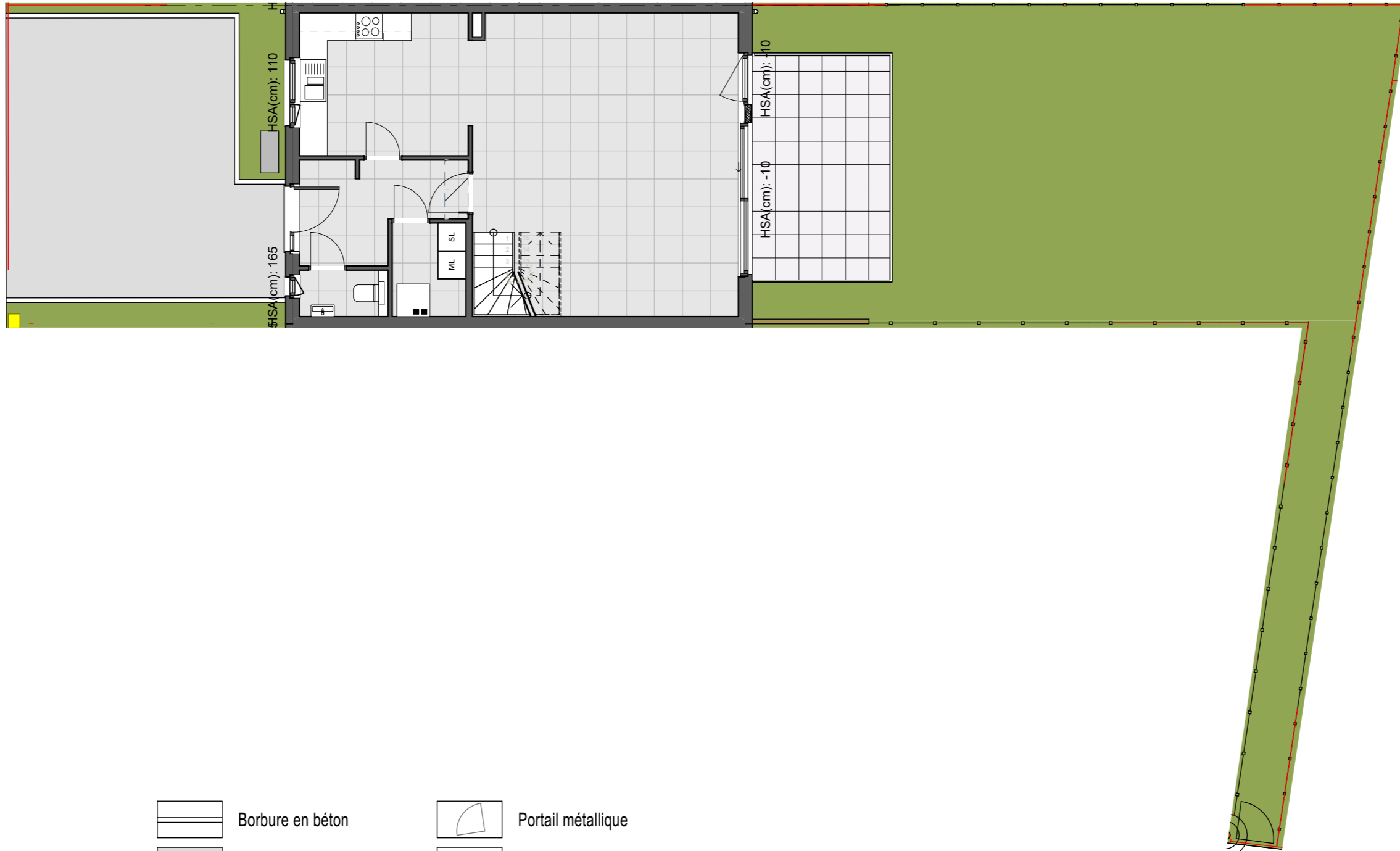

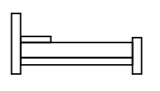
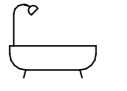
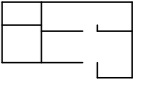
les deux  
écluses

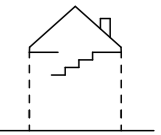

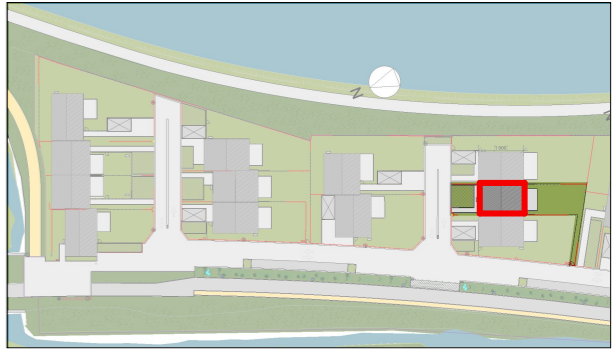
MAISON - LOT N2 (Type 5 bis)		
Implantation		
 3	 2	 136.4 m <sup>2</sup>
 212 m <sup>2</sup>	 44.5 m <sup>2</sup>	

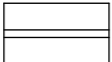
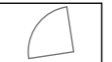

Rue Jean-Baptiste Vifquin  
7180 Seneffe

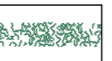
-  Borbure en béton
-  Portail métallique
-  Pavés de béton drainant
-  Haie

implantation 1/100 NO