

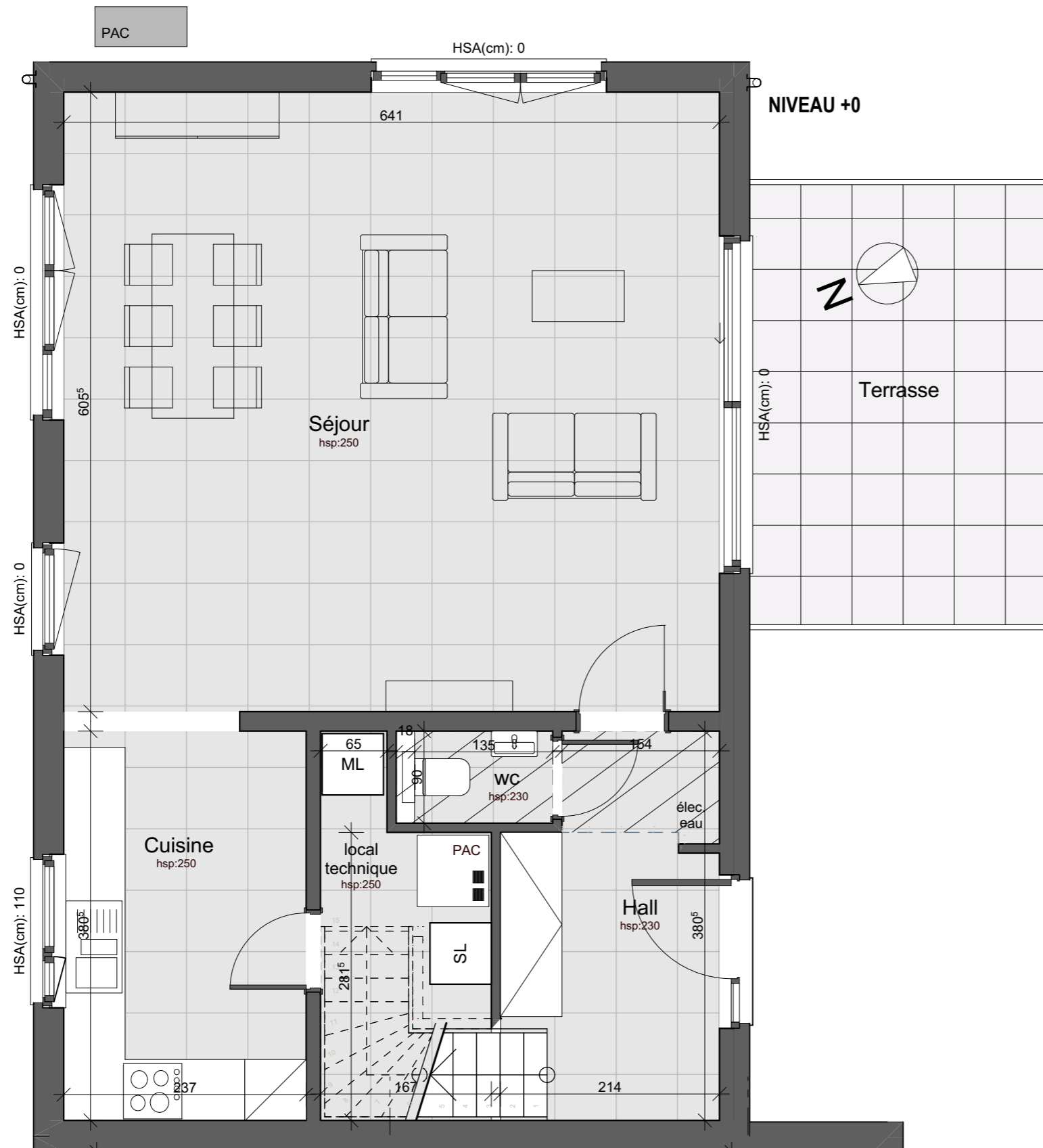

les deux
écluses

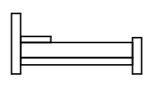

MAISON - LOT 07 (Type 10)		
Niveau +0		
 3	 2	 147 m ²
 374 m ²		 36.7 m ²

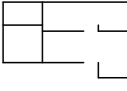
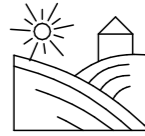
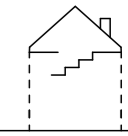

Rue Jean-Baptiste Vifquin
7180 Senefle





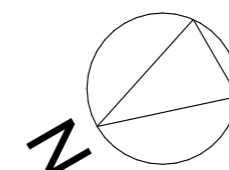

Drève Richelle, 161 D bte 19
B-1410 Waterloo
02 897 52 65 - www.equilis.net

- Document à titre d'information et non contractuel.
- Mobilier, machine à laver (ML) et sèche-linge (SL) non fournis.
- Les dimensions des cuisines et de leurs équipements sont données à titre d'information. Se référer aux plans contractuels des cuisines.
- Des faux-plafonds complémentaires pourront être placés à certains endroits pour des raisons techniques.
- Dimensions (distance entre murs avant plafonnage) données à titre indicatif.
- Ce qui est repris en pointillés sur les plans (vélux, aménagement des combles, etc.) n'est pas compris dans la vente.

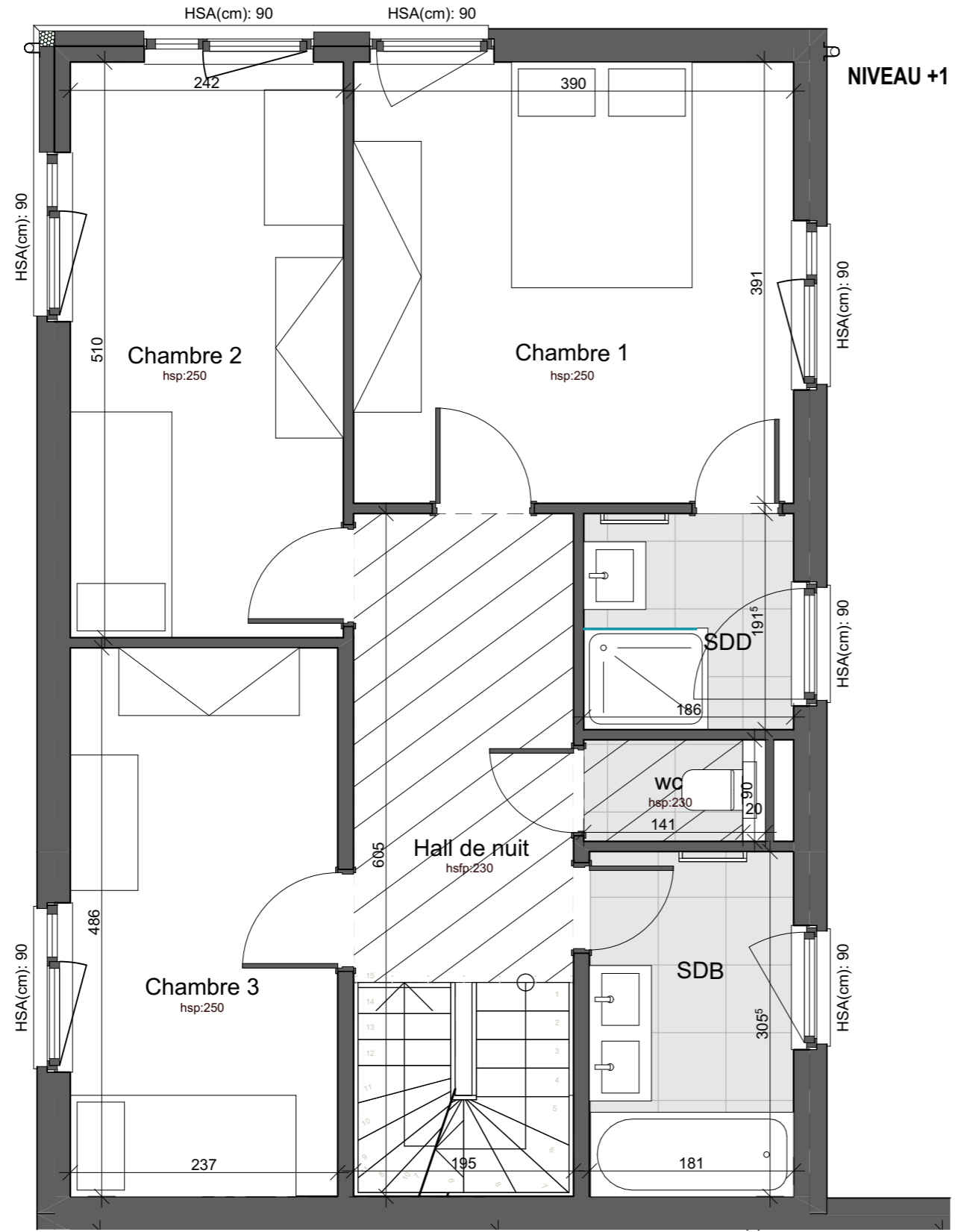

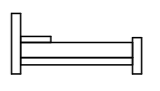
les deux
écluses

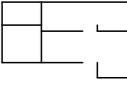

MAISON - LOT 07 (Type 10)		
Niveau +1		
 3	 2	 147 m ²
 374 m ²		 36.7 m ²

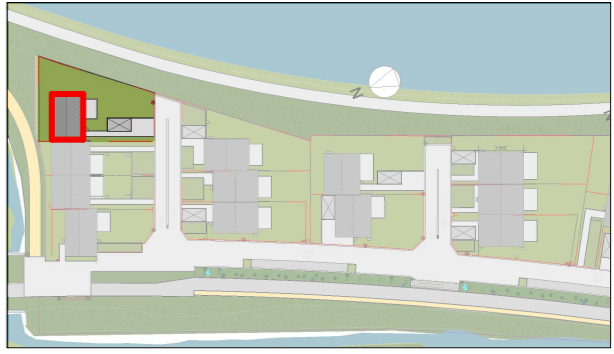



Rue Jean-Baptiste Vifquin
7180 Seneffe

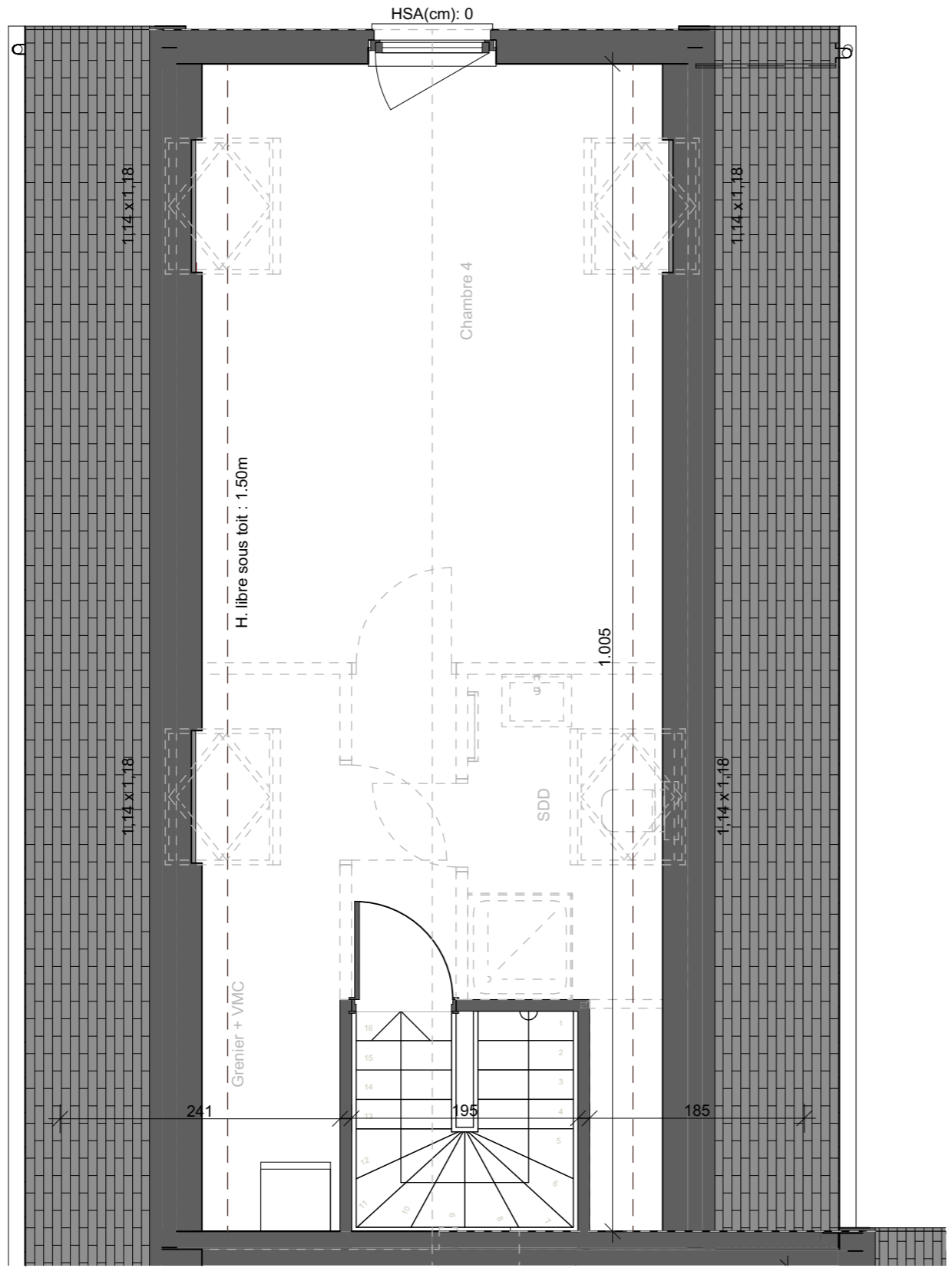

Drève Richelle, 161 D bte 19
B-1410 Waterloo
02 897 52 65 - www.equilis.net

les deux
écluses

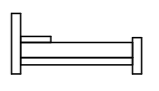
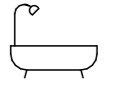
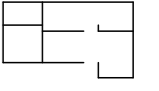

MAISON - LOT 07 (Type 10)		
Niveau +2		
 3	 2	 147 m ²
 374 m ²	 36.7 m ²	

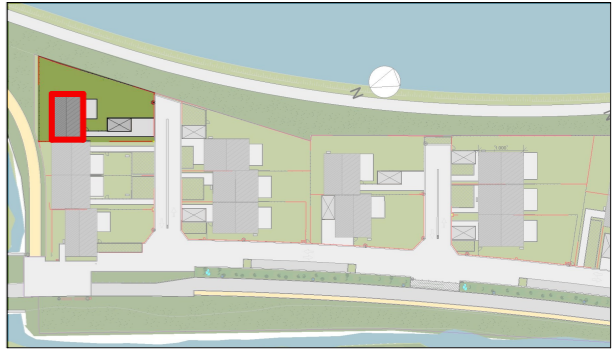

Rue Jean-Baptiste Vifquin
7180 Seneffe



Drève Richelle, 161 D bte 19
B-1410 Waterloo
02 897 52 65 - www.equilis.net

les deux

écluses





ELEVATIONNORD



ELEVATIONEST



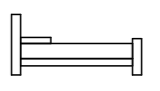

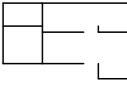
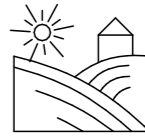
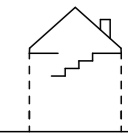

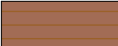

ELEVATIONSUD

MAISON - LOT 07 (Type 10)		
Elévations		
 3	 2	 147 m ²
 374 m ²	 36.7 m ²	



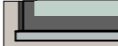

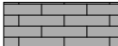
Rue Jean-Baptiste Vifquin
7180 Seneffe

-  Crépis lotusan de teinte blanche
-  Briquette synthétique STO teinte brun-gris
-  Châssis PVC de teinte anthracite
-  Bandeau métallique anthracite de liaison entre fenêtres

-  seuil pierre-bleue
-  rive: tuile micro-béton et plaque cedral board anthracite
-  Toiture en tuile micro-béton anthracite
-  gouttière et descentes d'eau zinc anthrazinc

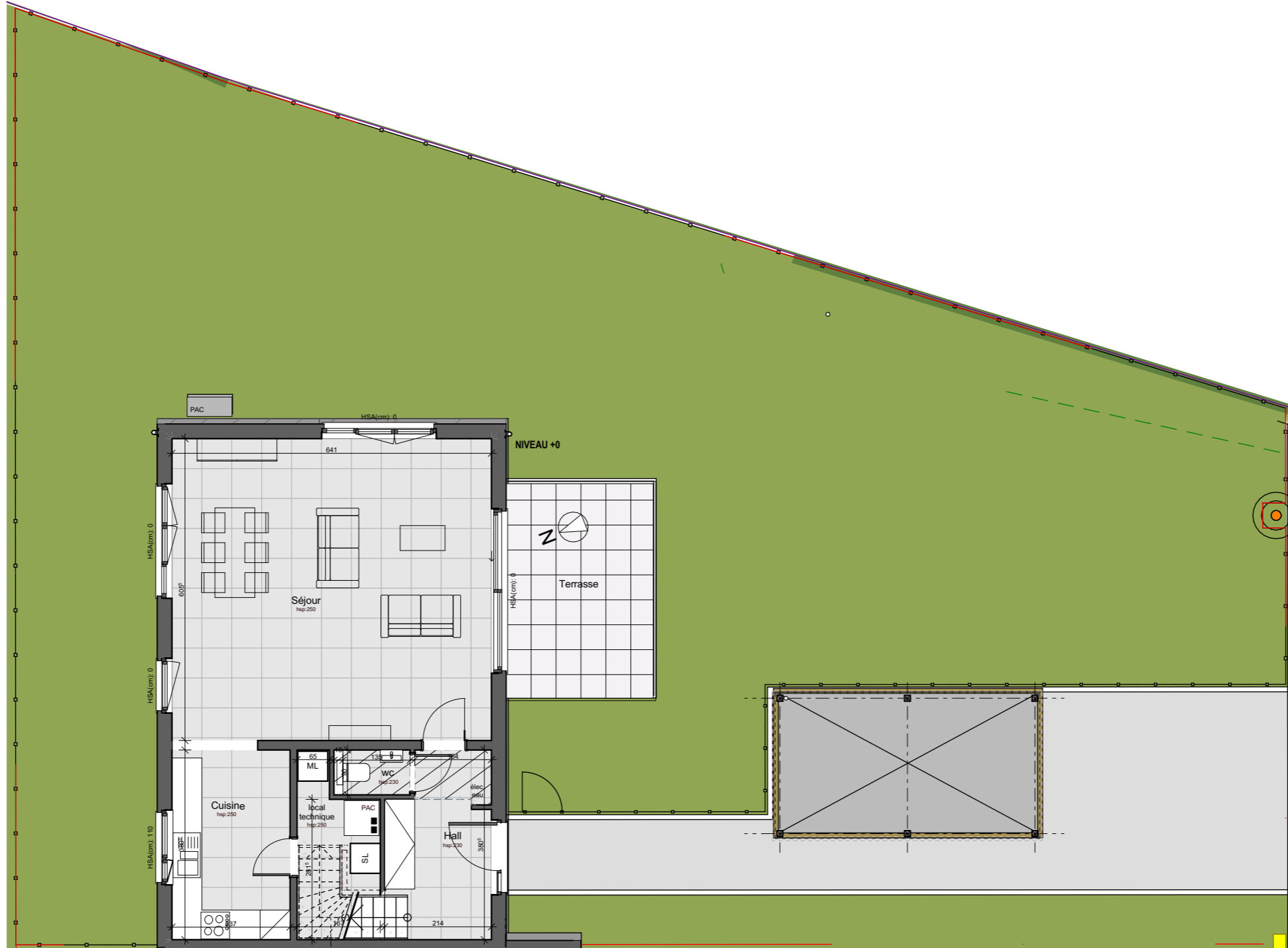
les deux écluses

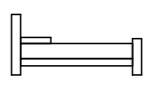
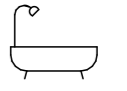
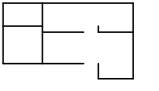

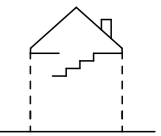
MAISON - LOT 07 (Type 10)		
Implantation		
 3	 2	 147 m ²
 374 m ²	 36.7 m ²	

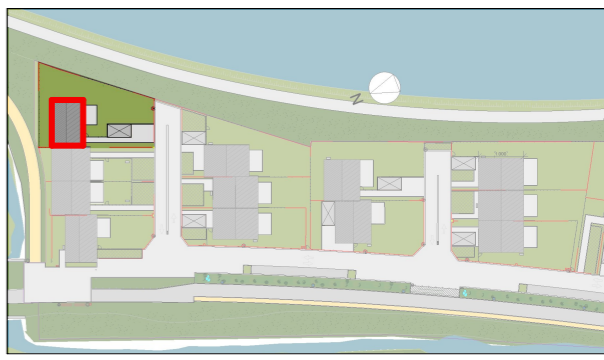

Rue Jean-Baptiste Vifquin
7180 Seneffe

-  Borbure en béton
-  Portail métallique
-  Pavés de béton drainant
-  Haie