 3	 2	 126.2 m ²
 47.9 m ²		

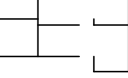
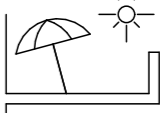
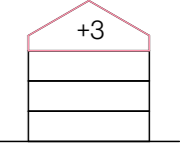
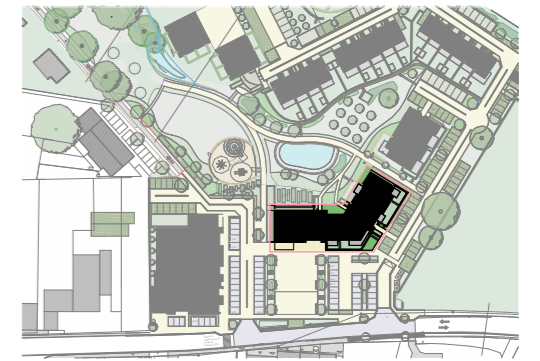
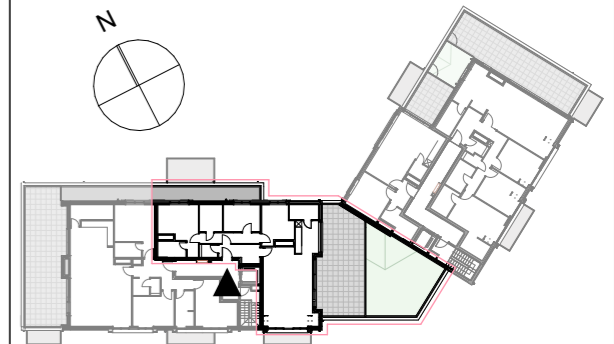

MISAJOURLE: / /

SIGNATURE:

POUR ACCORD:

DATE