

2	1	97.8m <sup>2</sup>
		
11.8m <sup>2</sup>		

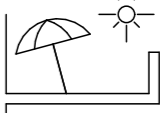
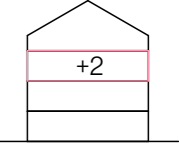
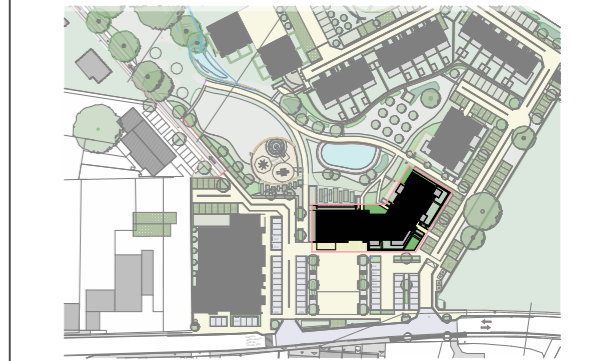
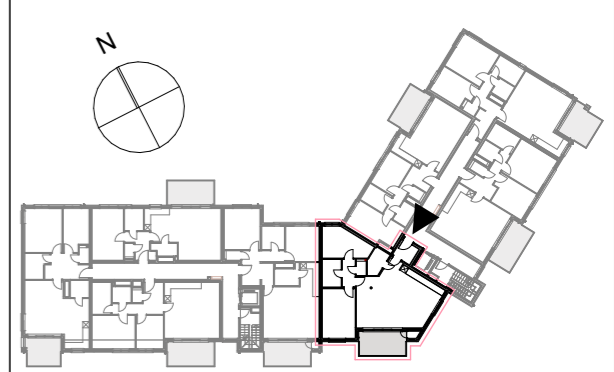

MISA JOURLE: / /

SIGNATURE:

POUR ACCORD:

DATE