

Draairichting buitenschrijnwerk volgens keuze bouwheer
 Glas en valbeveiliging volgens norm te voorzien.





Draairichting buitenschrijnwerk volgens keuze bouwheer
 Glas en valbeveiliging volgens norm te voorzien.



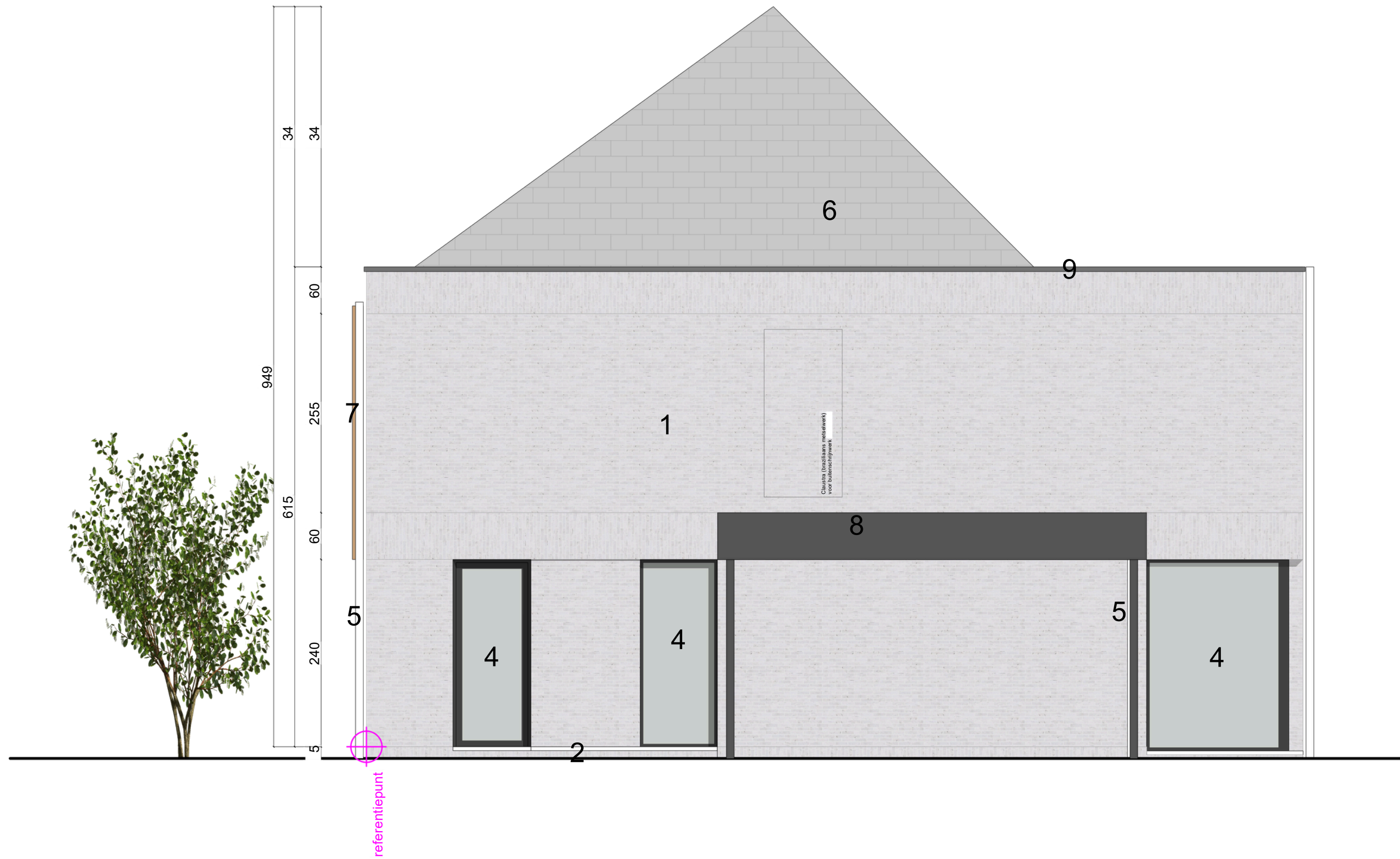

Draairichting buitenschrijnwerk volgens keuze bouwheer
 Glas en valbeveiliging volgens norm te voorzien.



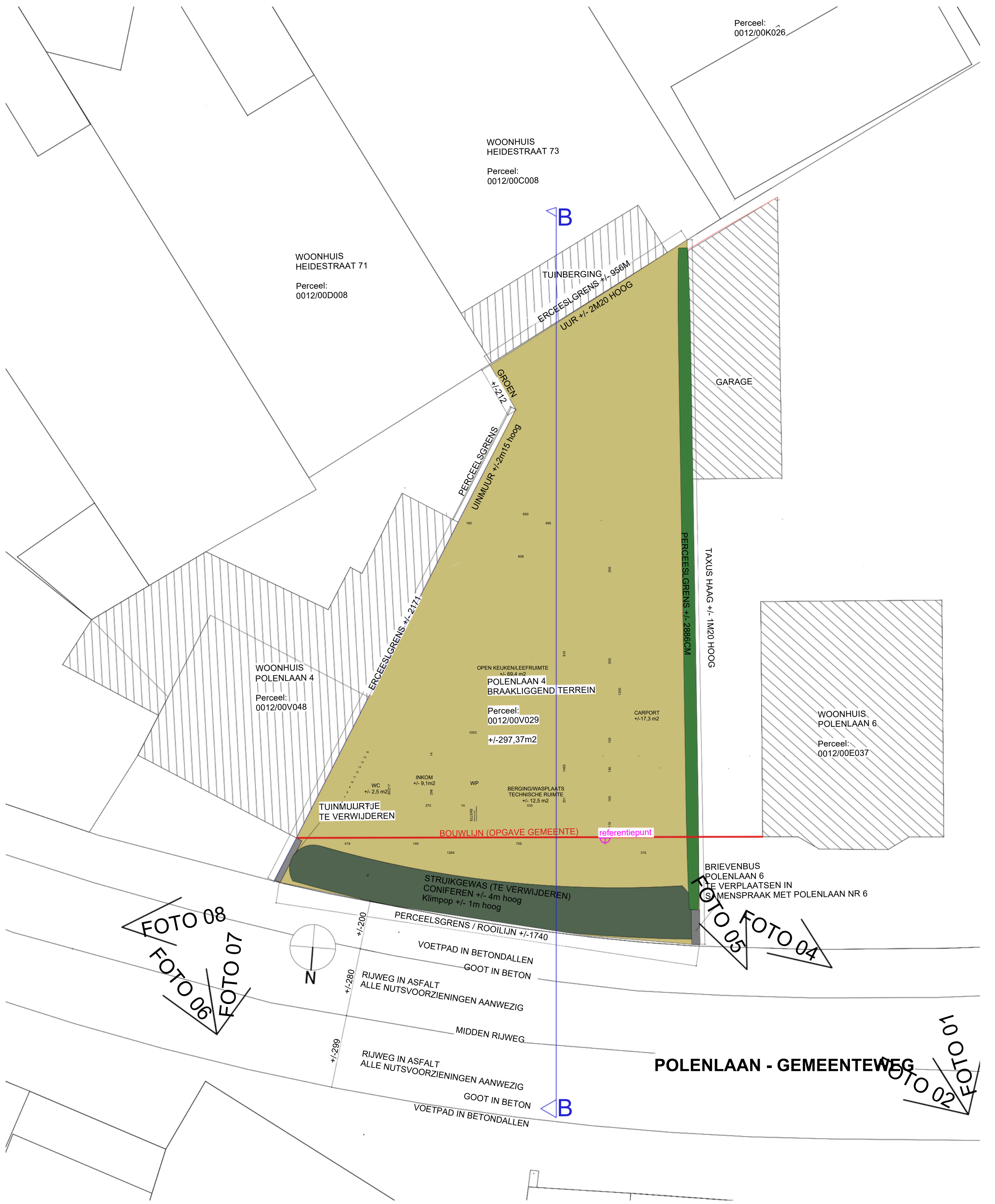

Perceel:
0012/00K026

WOONHUIS
HEIDESTRAAT 73
Perceel:
0012/00C008

WOONHUIS
HEIDESTRAAT 71
Perceel:
0012/00D008

WOONHUIS
POLENLAAN 4
Perceel:
0012/00V048

WOONHUIS
POLENLAAN 4
BRAAKLIGGEND TERREIN
Perceel:
0012/00V029
+/-297,37m2

WOONHUIS
POLENLAAN 6
Perceel:
0012/00E037

BRIEVENBUS
POLENLAAN 6
TE VERPLAATSEN IN
S A MENS PRAAK MET POLENLAAN NR 6

FOTO 08
FOTO 06
FOTO 07

FOTO 05
FOTO 04

FOTO 01
FOTO 02

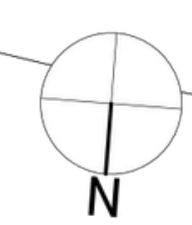

1m 5m

Perceel:
0012/00K026

WOONHUIS
HEIDESTRAAT 73

Perceel:
0012/00C008

WOONHUIS
HEIDESTRAAT 71

Perceel:
0012/00D008

WOONHUIS
POLENLAAN 4

Perceel:
0012/00V048

WOONHUIS
POLENLAAN 4
BRAAKLIGGEND TERREIN

Perceel:
0012/00V029

WOONHUIS
POLENLAAN 6

Perceel:
0012/00E037

PLAN OP BASIS VAN LANDMETERSPLAN BEZORGD DOOR BOUWHEER
GRENZEN TER PLAATSE TE CONTROLEREN DOOR ERKENDE LANDMETER
UITZETTING GEBOUW DOOR ERKENDE LANDMETER.

0 1m 5m

BOUWPLAATS

Polenlaan 4
9170 De Klinge

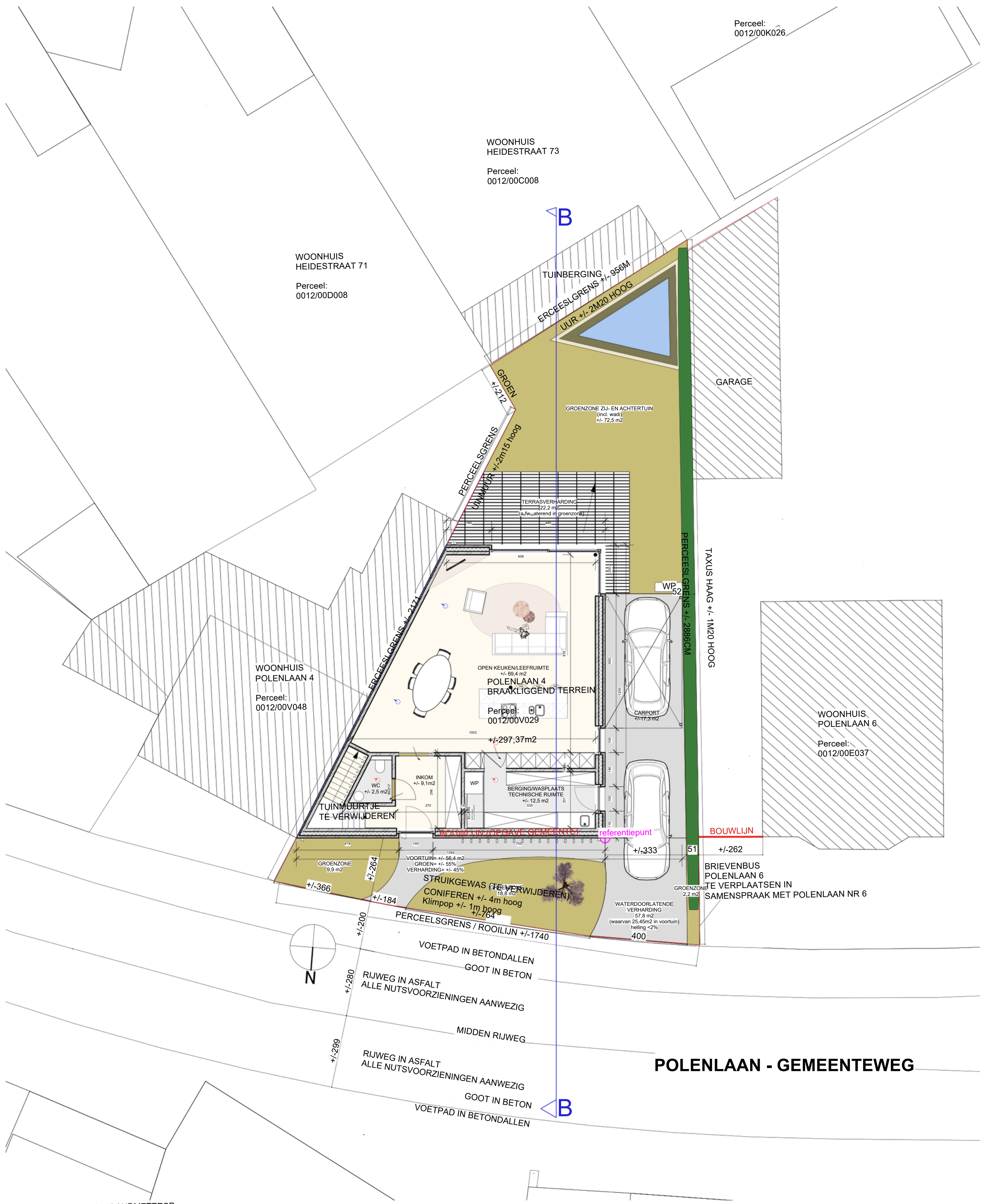

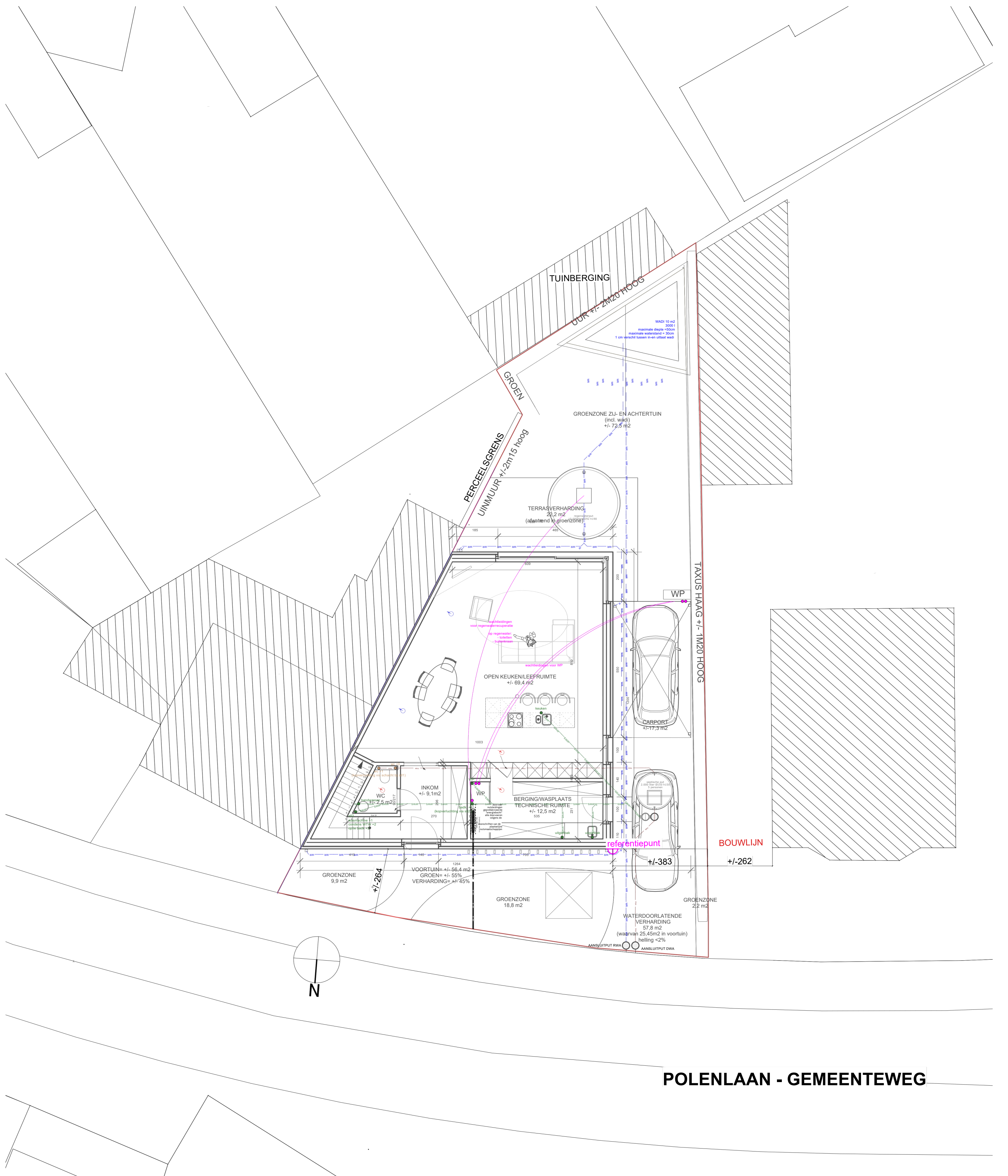

PLAN OP BASIS VAN LANDMETERSPLAN BEZORGD DOOR BOUWHEER
 GRENZEN TER PLAATSE TE CONTROLEREN DOOR ERKENDE LANDMETERS
 UITZETTING GEBOUW DOOR ERKENDE LANDMETERS

0 1m 5m

BOUWPLAATS
 Polenlaan 4
 9170 De Klinge

GEVELMATERIALEN

- 1 LICHTE GEVELSTEEN
- 2 DORPEL/PLINT IN BLAUWE HARDSTEEN
- 3 ALUMINIUM DORPEL
- 4 BUITENSCHRIJNWERK DONKER PVC OF ALU
- 5 STANDPIJP/DAKGOOT IN ZINK
- 6 DAK-/GEVELPAN LICHTE KLEUR
- 7 LAMMELEN IN HOUT
- 8 ALUMINIUM GEVELBEKLEDING DONKER
- 9 ALUMINIUM DAKRANDPROFIEL DONKER
- 10 GEVELLEIEN LICHTE KLEUR

ALGEMEEN

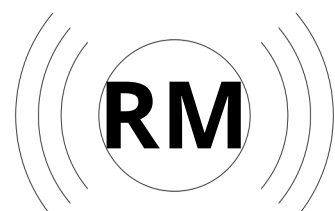

AUTONOME ROOKMELDER (verplicht)



REFERENTIEPUNT



SCHAALLAT

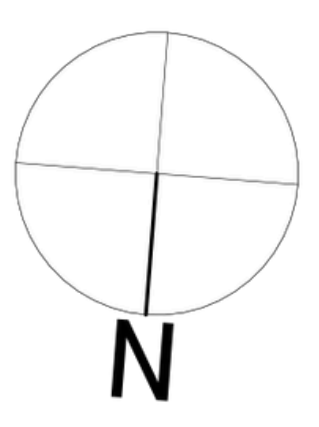
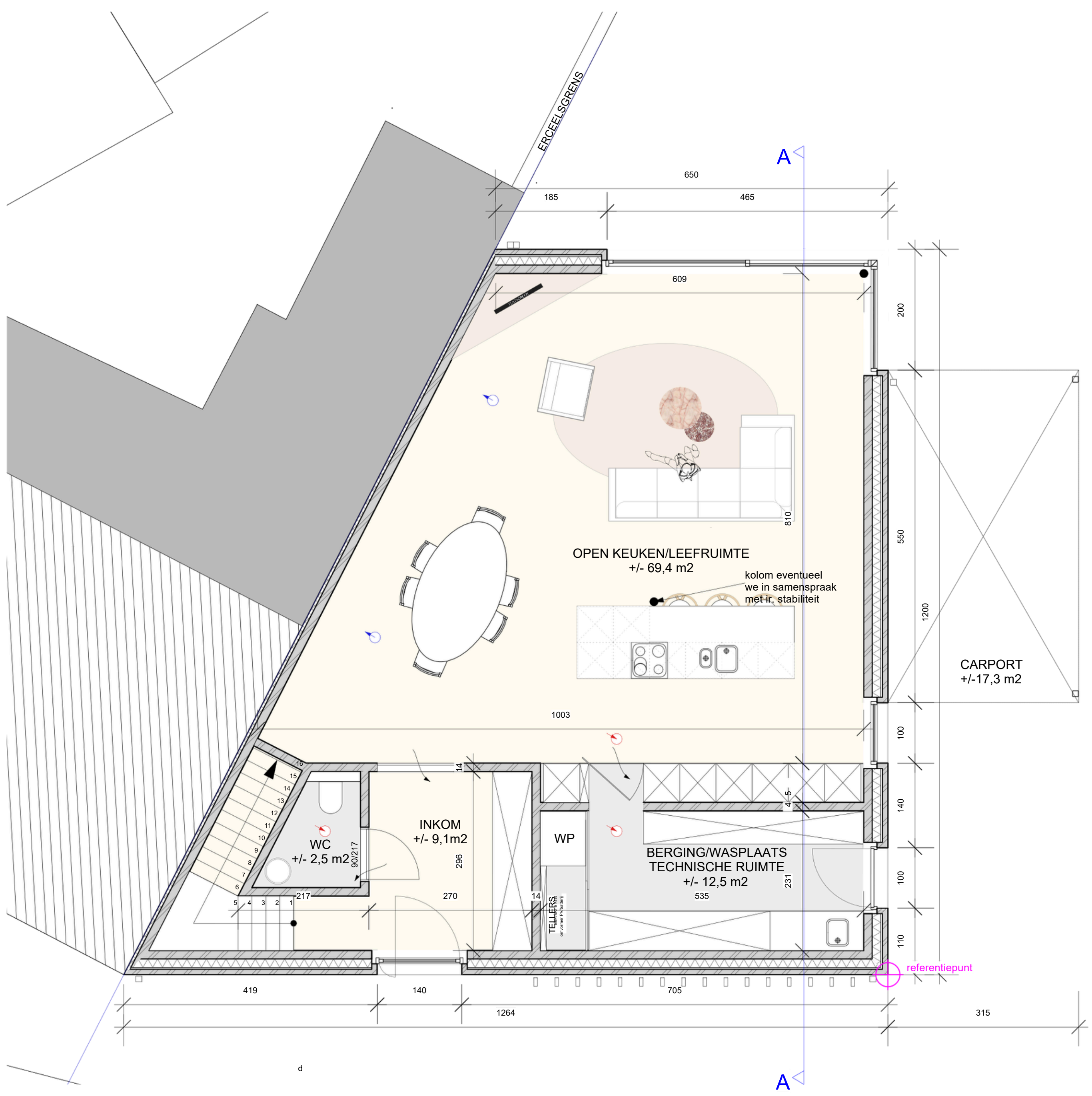

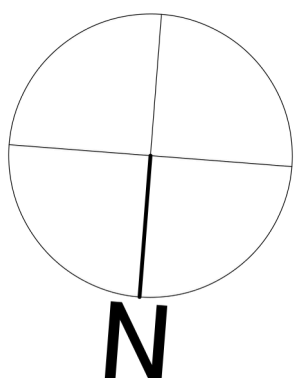
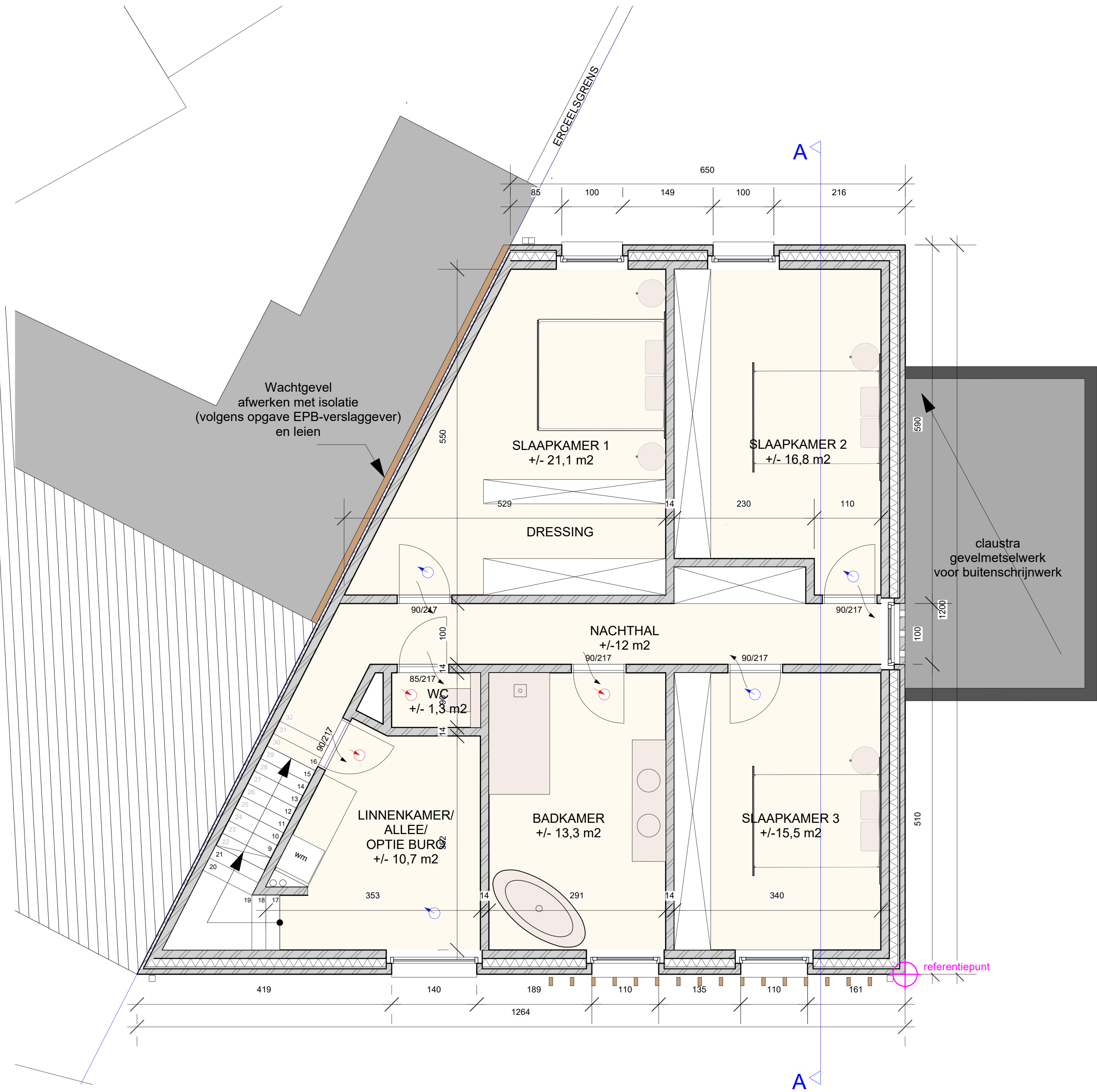

0 1m 5m

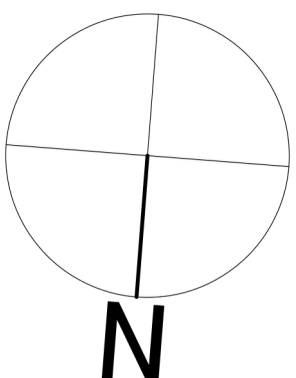
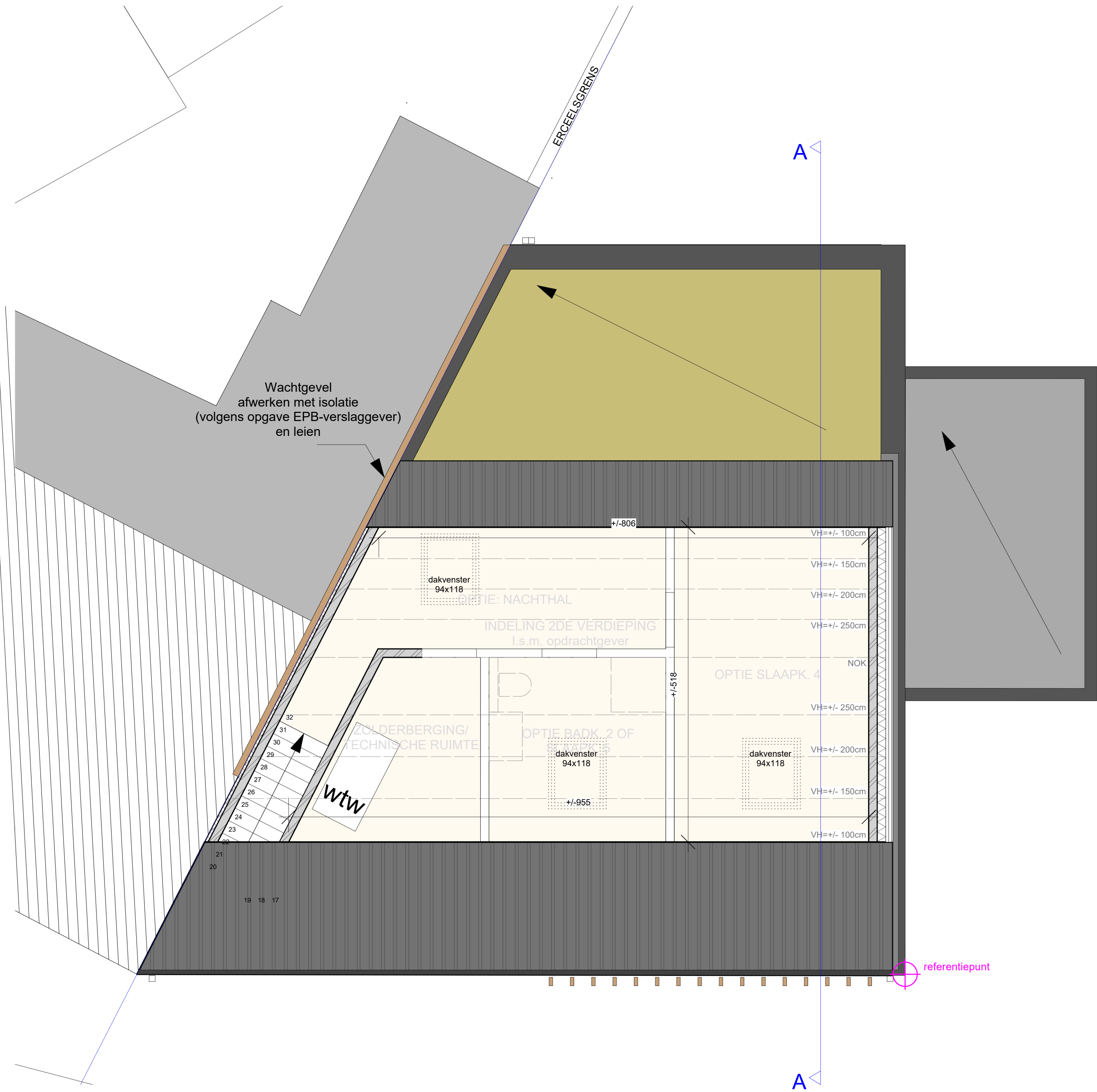

0 1m 5m

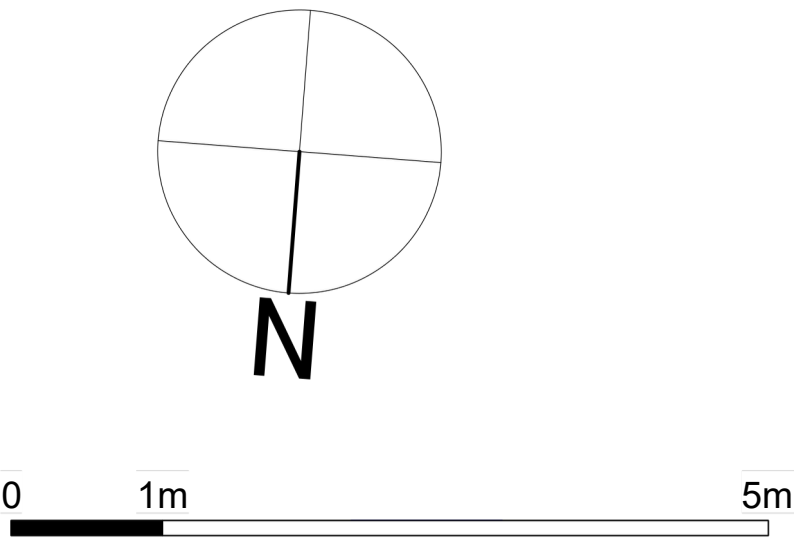

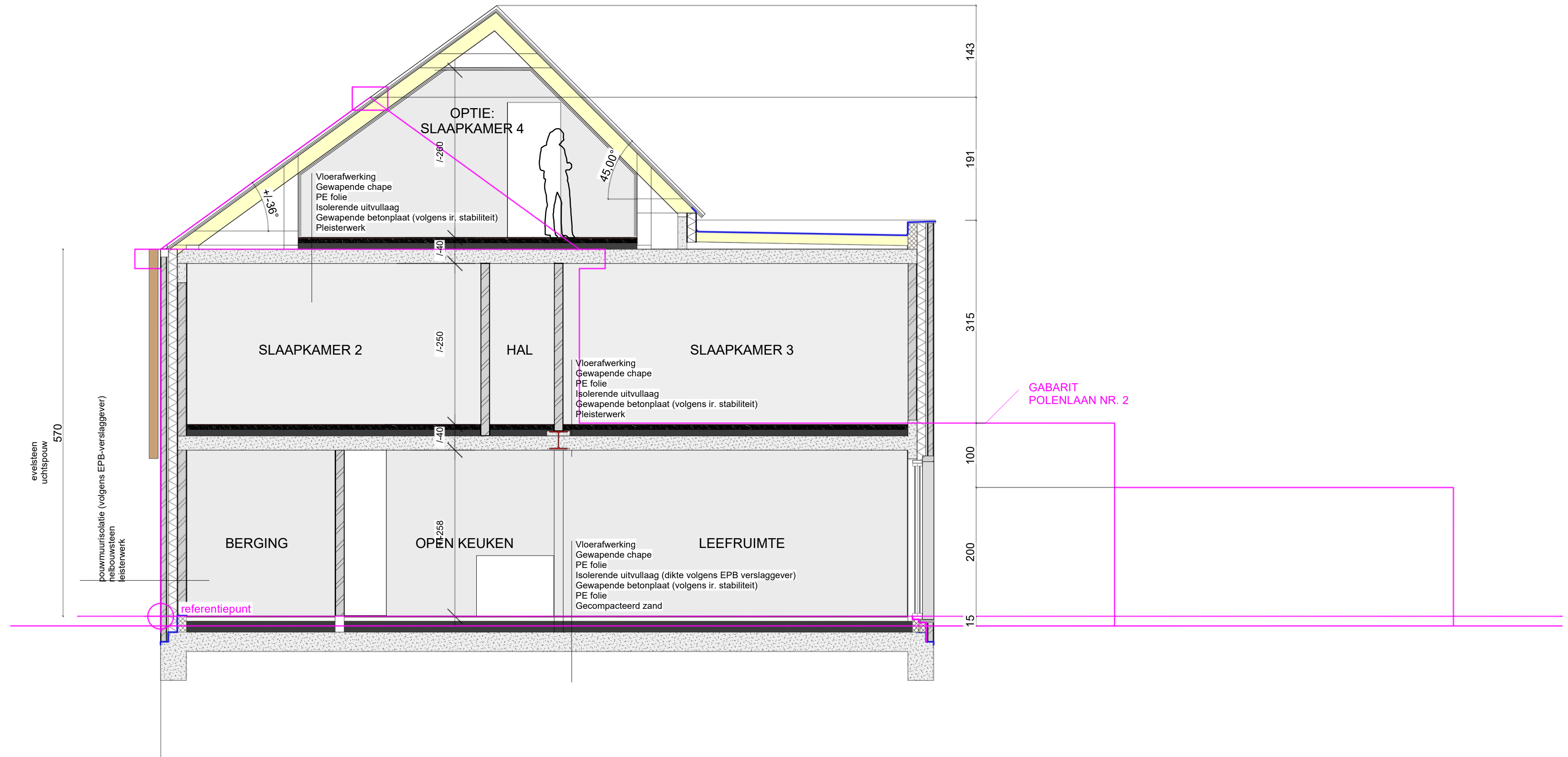

0 1m 5m

TERRASVERHARDING

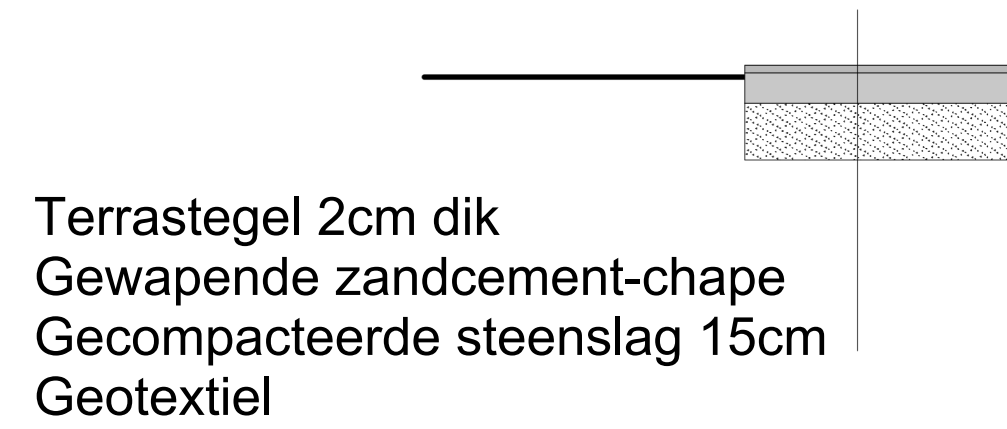

Terrastegel 2cm dik
Gewapende zandcement-chape
Gecompacteerd steenslag 15cm
Geotextiel

WATERDOORLATEND VERHARDING

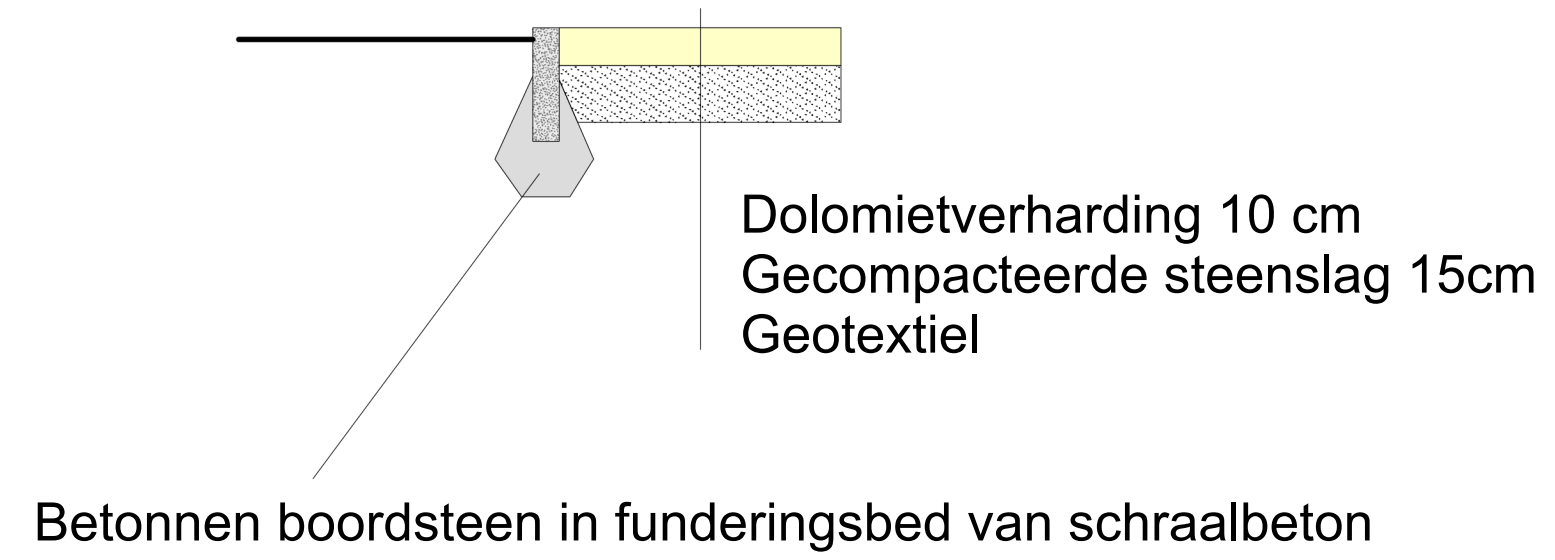

Dolomietverharding 10 cm
Gecompacteerd steenslag 15cm
Geotextiel

Betonnen boordsteen in funderingsbed van schraalbeton

PRICIPESNEDE WADI

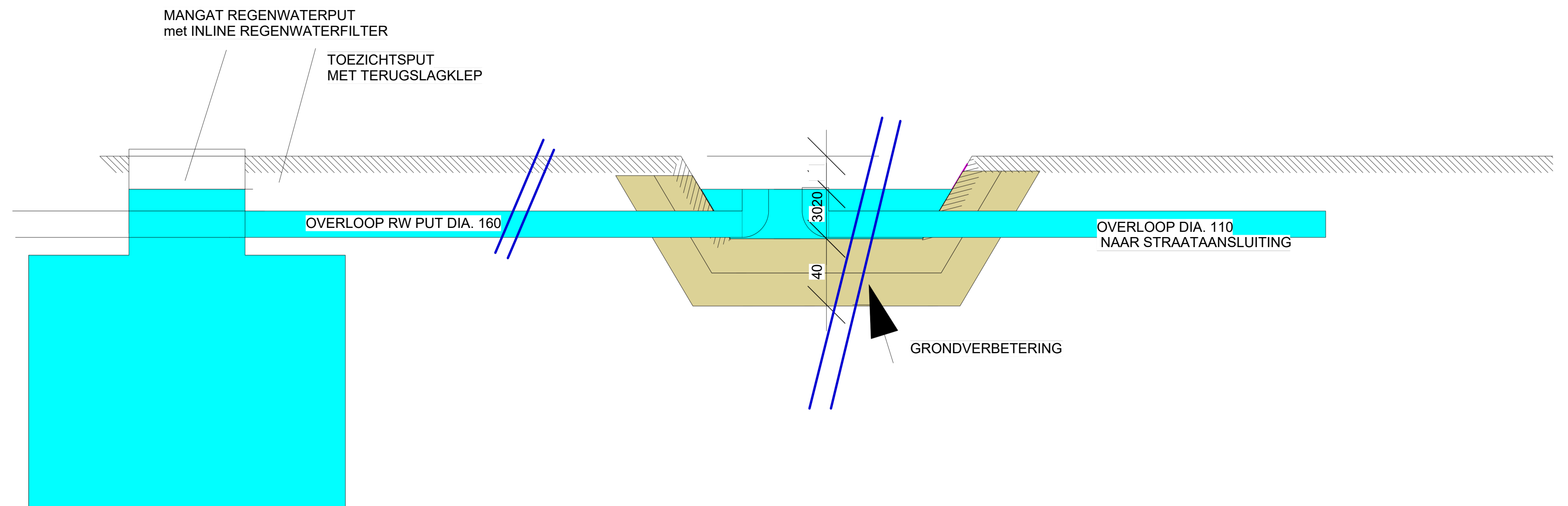

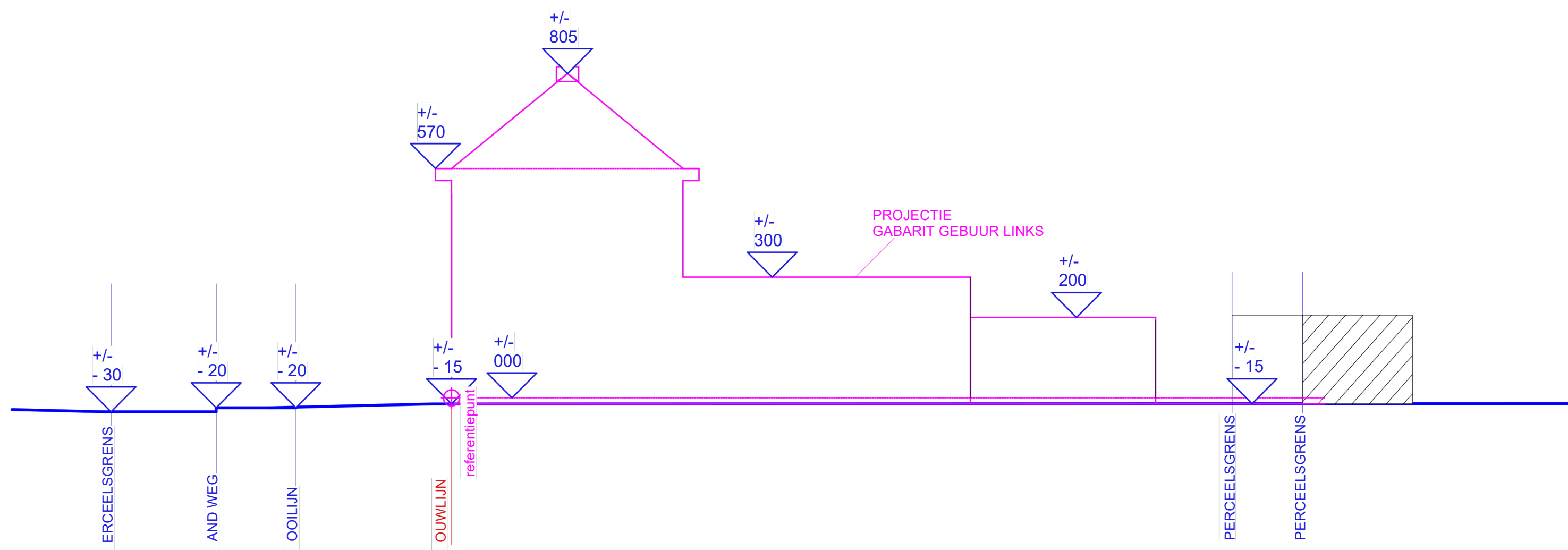

01m 5m

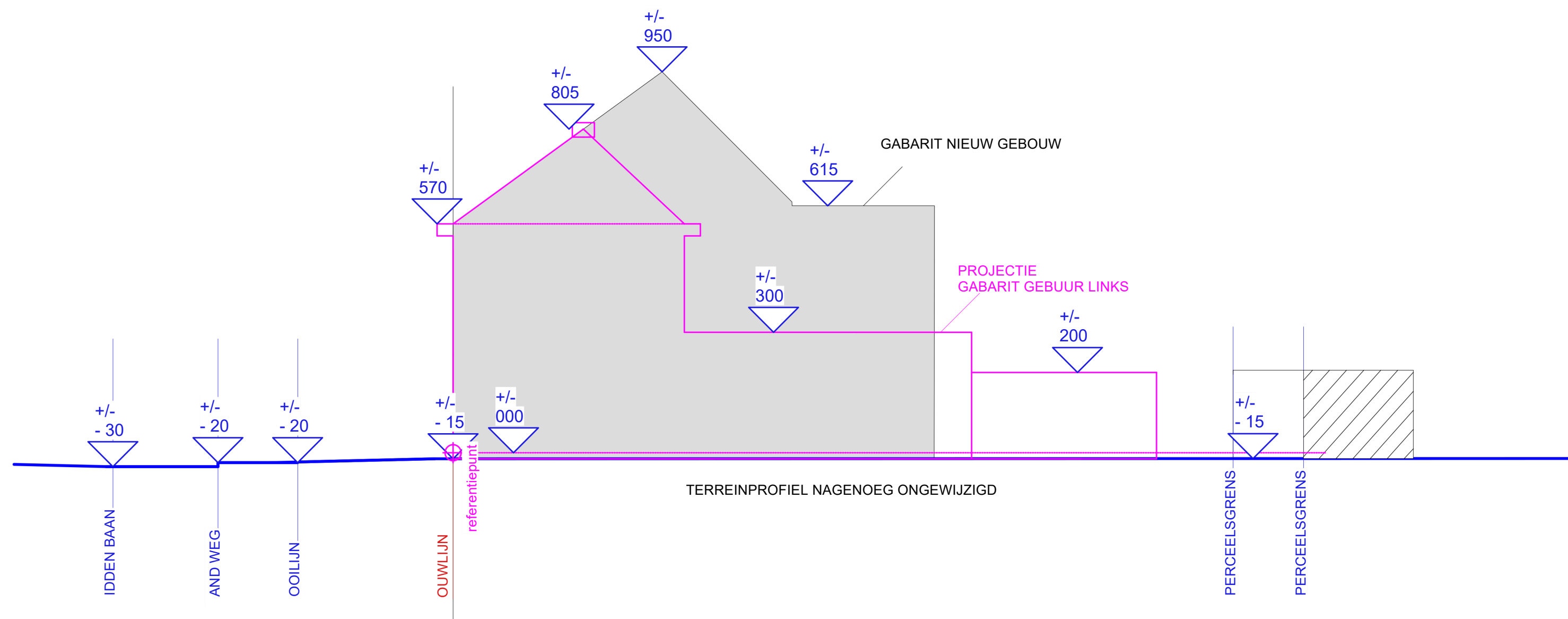

01m 5m