

# S29818

**CRÉÉ LE**  
1 avril 2026

<b>Surface totale</b> 109.51 m <sup>2</sup>	<b>Étages</b> 2	<b>Pièces</b> 8	<b>Salle de bains</b> 0
--	--------------------	--------------------	----------------------------

▼ **Rez-de-chaussée**

SURFACE TOTALE : 71.94 m<sup>2</sup> • SURFACE HABITABLE : 34.00 m<sup>2</sup> • PIÈCES : 4

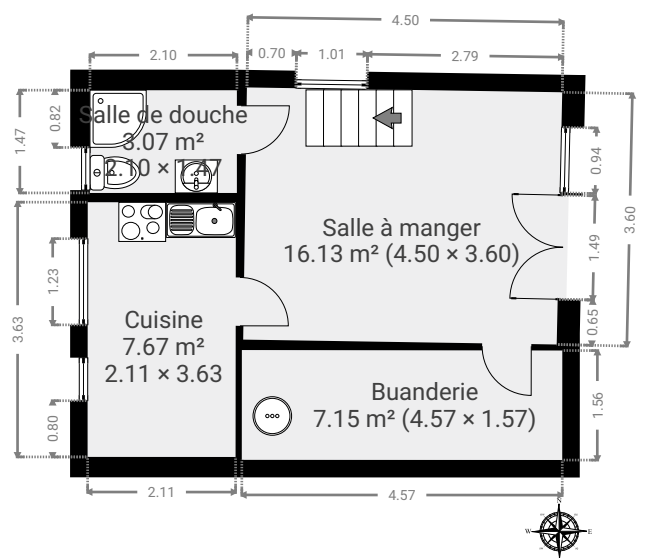
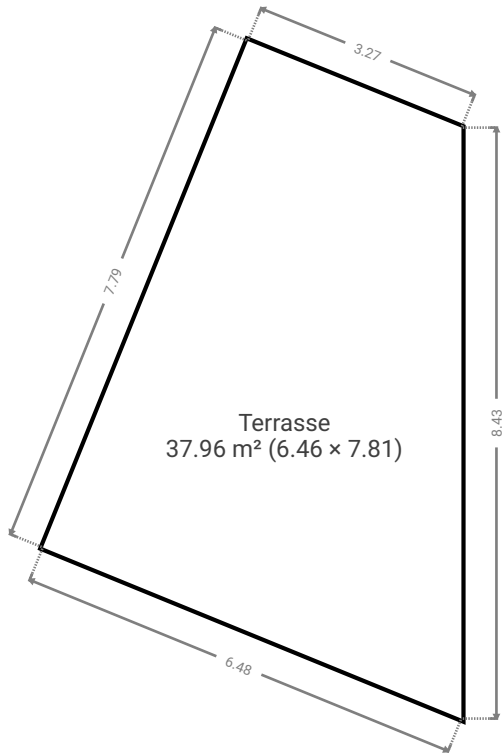

▼ **Buanderie**  
Rez-de-chaussée

LARGEUR : 4.57 m • LONGUEUR : 1.57 m  
SURFACE : 7.15 m<sup>2</sup> • PÉRIMÈTRE : 12.27 m

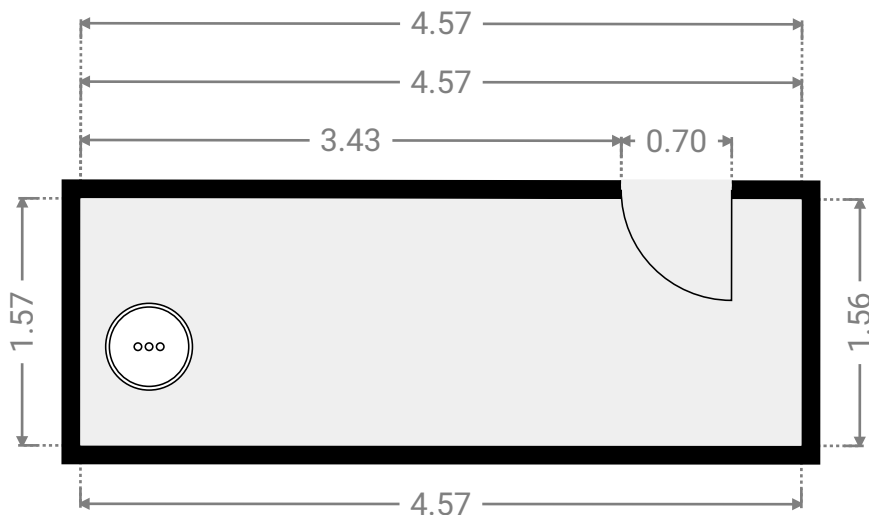
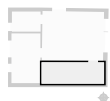

▼ **Cuisine**  
Rez-de-chaussée

LARGEUR : 2.11 m • LONGUEUR : 3.63 m  
SURFACE : 7.67 m<sup>2</sup> • PÉRIMÈTRE : 11.49 m

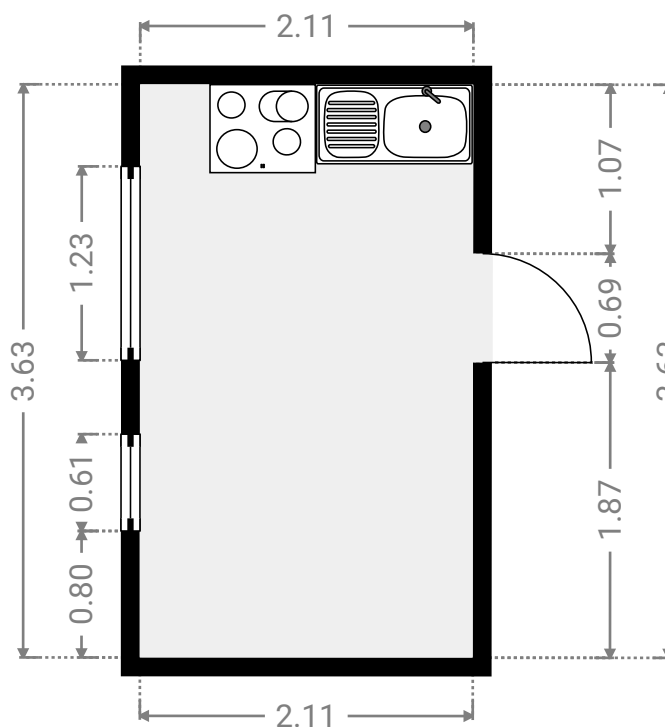

▼ **Salle de douche**  
Rez-de-chaussée

LARGEUR : 2.10 m • LONGUEUR : 1.47 m  
SURFACE : 3.07 m<sup>2</sup> • PÉRIMÈTRE : 7.12 m

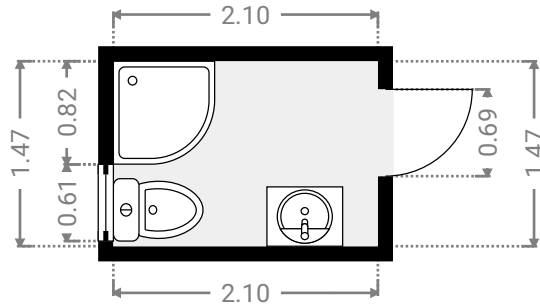
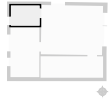

▼ **Salle à manger**  
Rez-de-chaussée

LARGEUR : 4.50 m • LONGUEUR : 3.60 m  
SURFACE : 16.13 m<sup>2</sup> • PÉRIMÈTRE : 16.16 m

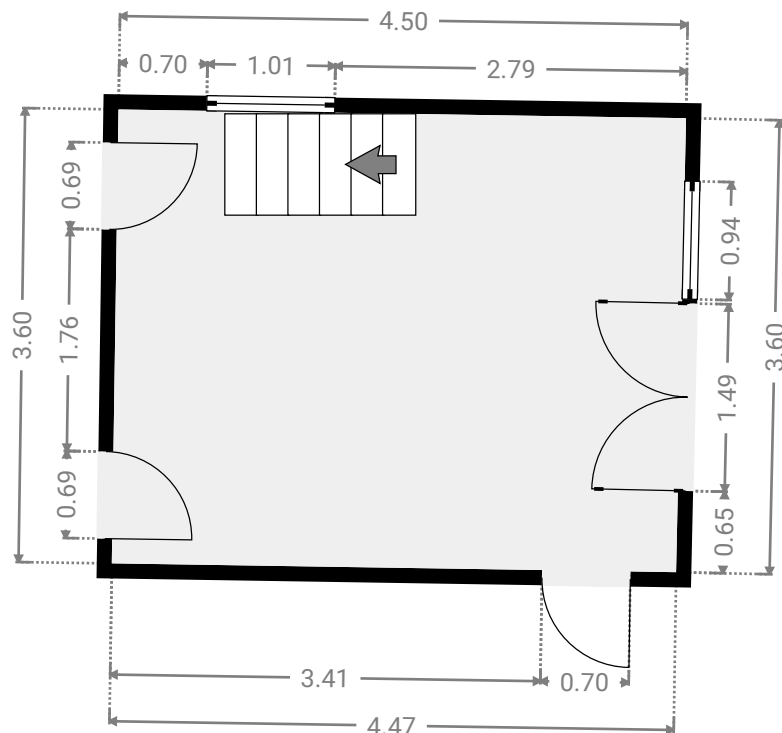
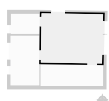

▼ **Terrasse**  
Rez-de-chaussée

LARGEUR : 6.46 m • LONGUEUR : 7.81 m  
SURFACE : 37.96 m<sup>2</sup> • PÉRIMÈTRE : 25.95 m

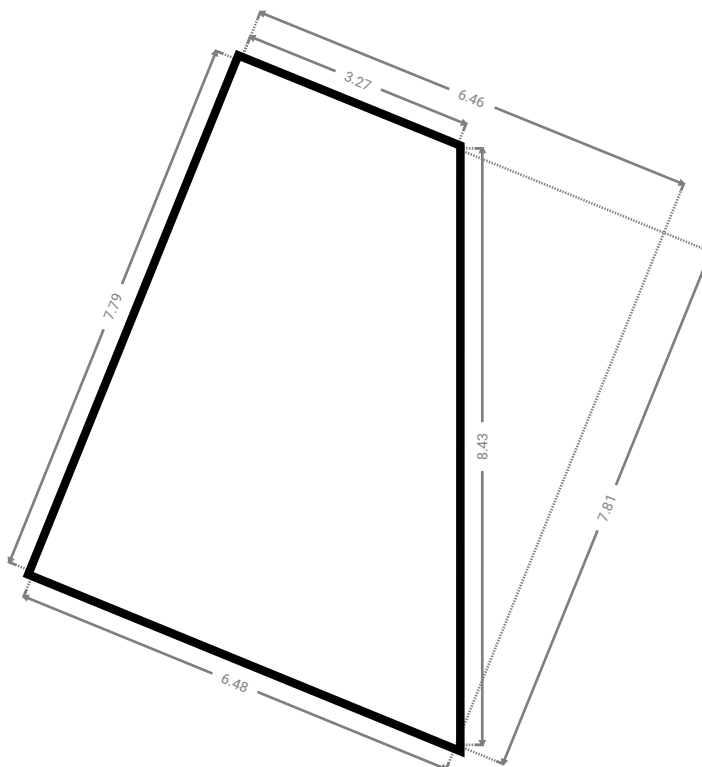
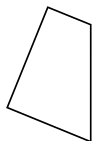

▼ 1er étage

SURFACE TOTALE : 37.57 m<sup>2</sup> • SURFACE HABITABLE : 29.72 m<sup>2</sup> • PIÈCES : 4

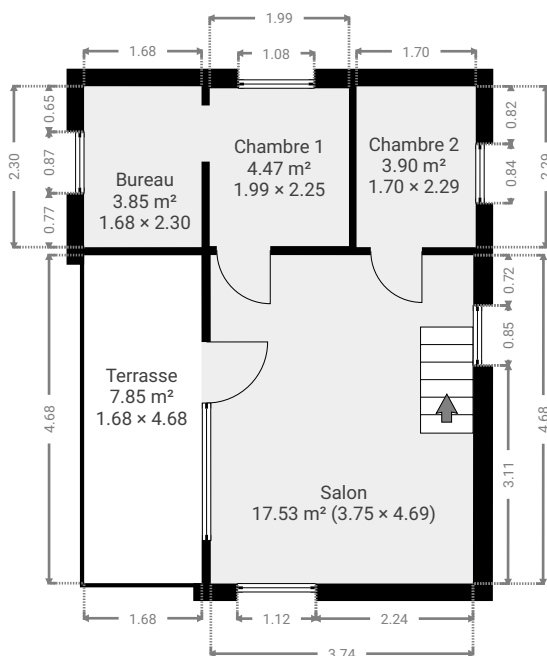

▼ Bureau  
1er étage

LARGEUR : 2.30 m • LONGUEUR : 1.68 m  
SURFACE : 3.85 m<sup>2</sup> • PÉRIMÈTRE : 7.94 m

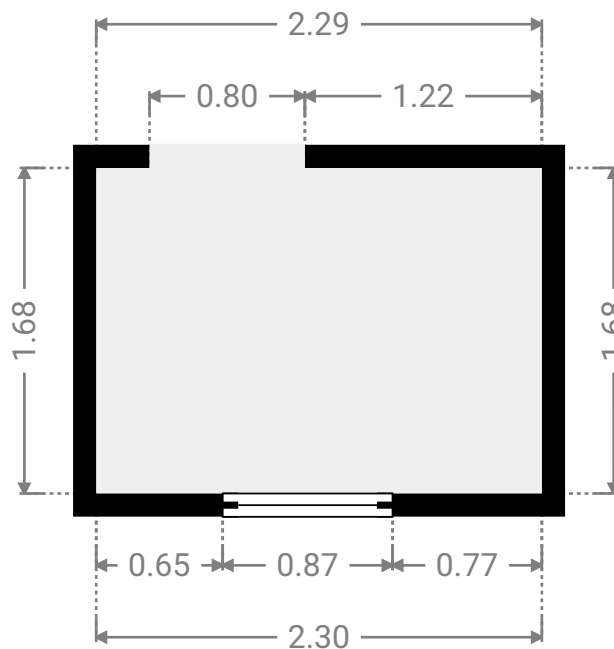
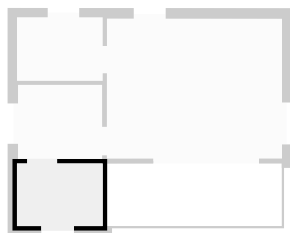

▼ Chambre 1  
1er étage

LARGEUR : 2.25 m • LONGUEUR : 1.99 m  
SURFACE : 4.47 m<sup>2</sup> • PÉRIMÈTRE : 8.47 m

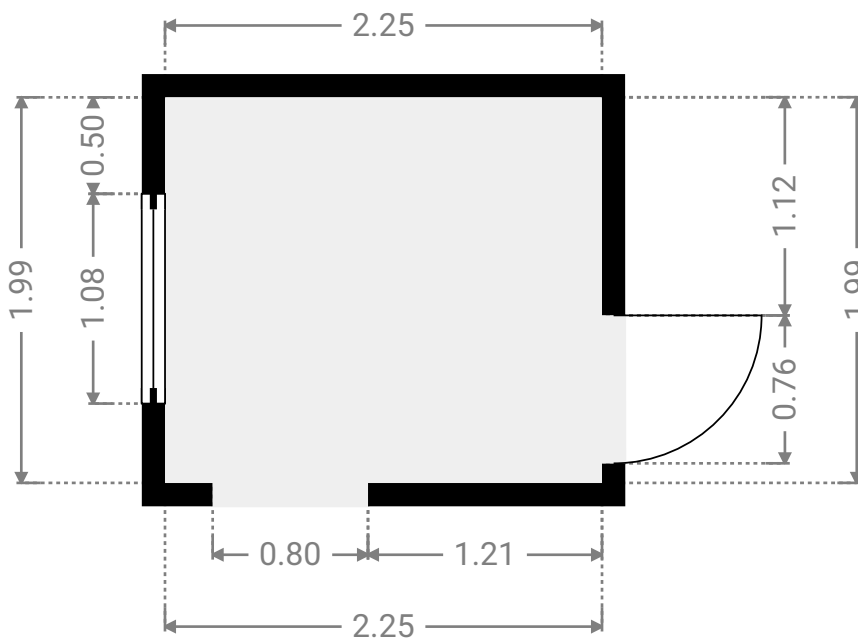
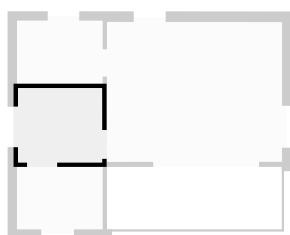

▼ **Chambre 2**  
1er étage

LARGEUR : 2.29 m • LONGUEUR : 1.70 m  
SURFACE : 3.90 m<sup>2</sup> • PÉRIMÈTRE : 7.99 m

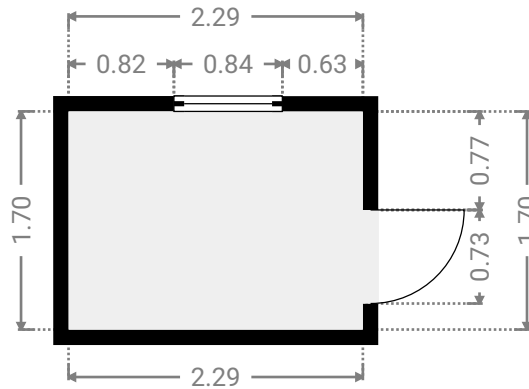
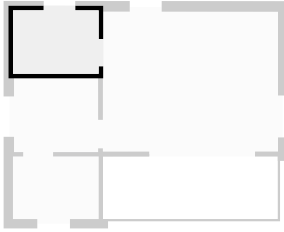

▼ **Salon**  
1er étage

LARGEUR : 4.69 m • LONGUEUR : 3.75 m  
SURFACE : 17.53 m<sup>2</sup> • PÉRIMÈTRE : 16.85 m

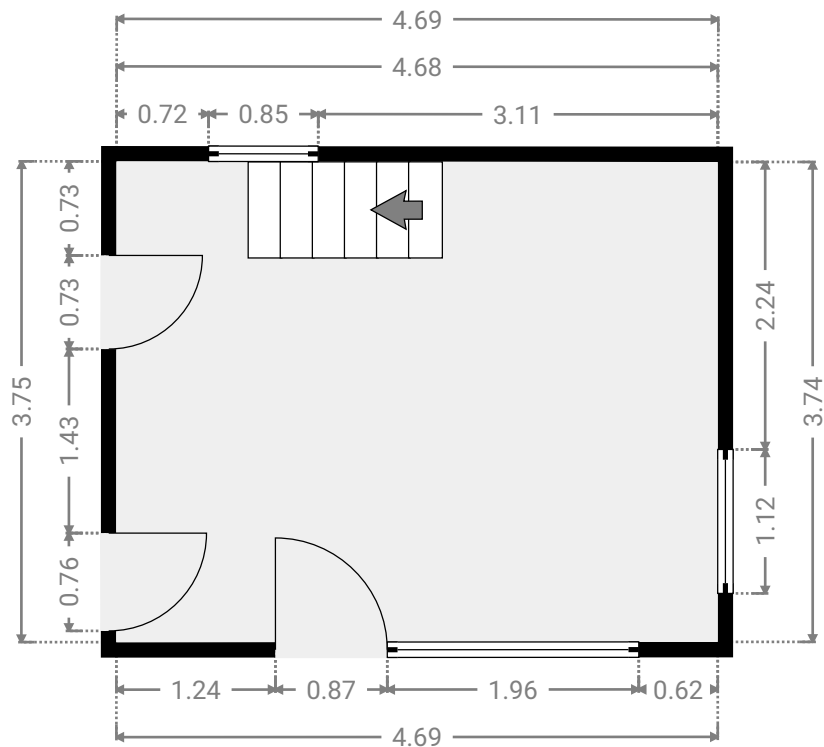
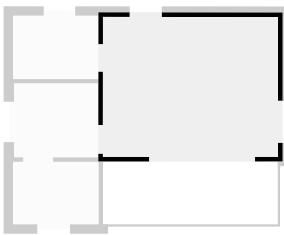

▼ **Terrasse**  
1er étage

LARGEUR : 4.68 m • LONGUEUR : 1.68 m  
SURFACE : 7.85 m<sup>2</sup> • PÉRIMÈTRE : 12.71 m

